

LIMITS	DEGREE CLASS	DEGREE CLASS			
		A	B	C	D
10 以下		±0.02	±0.05	±0.10	±0.15
10~50 以下		±0.05	±0.10	±0.15	±0.20
50~120 以下		±0.10	±0.15	±0.20	±0.25
120~300 以下		±0.15	±0.20	±0.25	±0.30
300~500 以下		±0.20	±0.25	±0.30	±0.35
500~1000 以下		±0.25	±0.30	±0.35	±0.40
1000~1500 以下		±0.30	±0.35	±0.40	±0.45
ANGEL		±0.2°	±0.5°	±1.0°	±1.5°

ZONE REV.	DESCRIPTION	DATE	APPROVED
A	INITIAL RELEASE	2014.05.30	ZhouGao

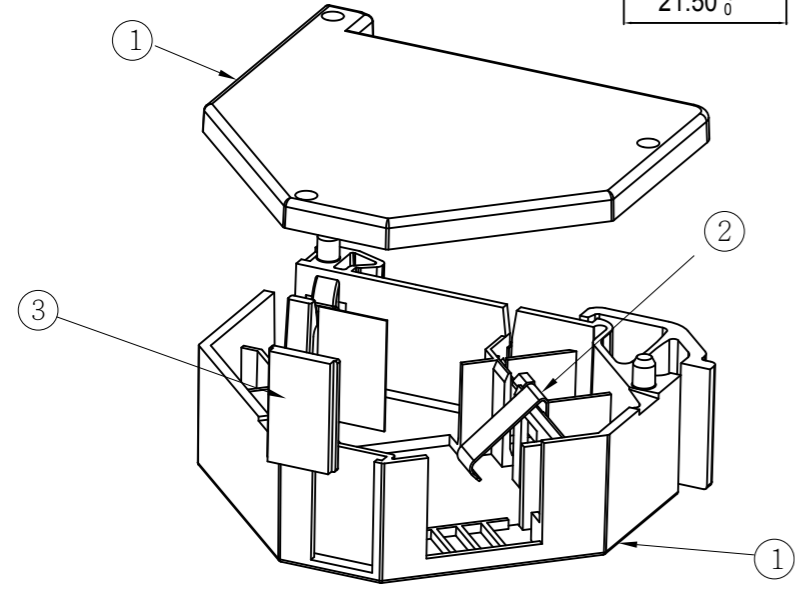
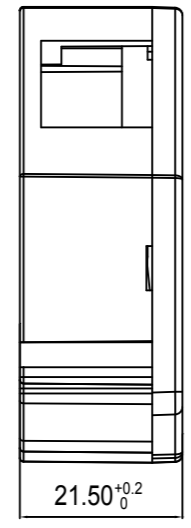
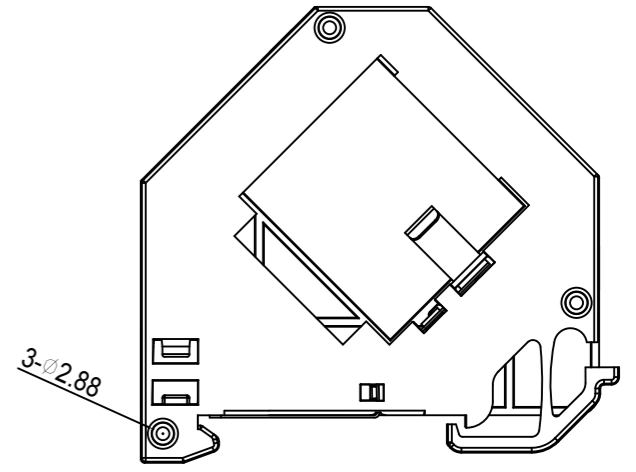
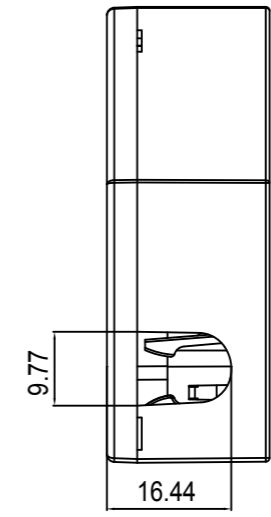
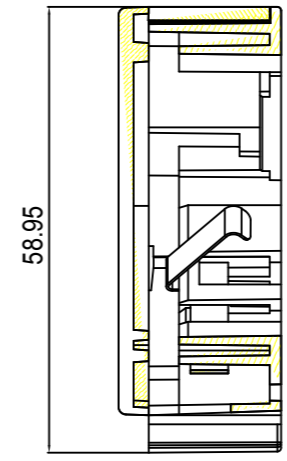
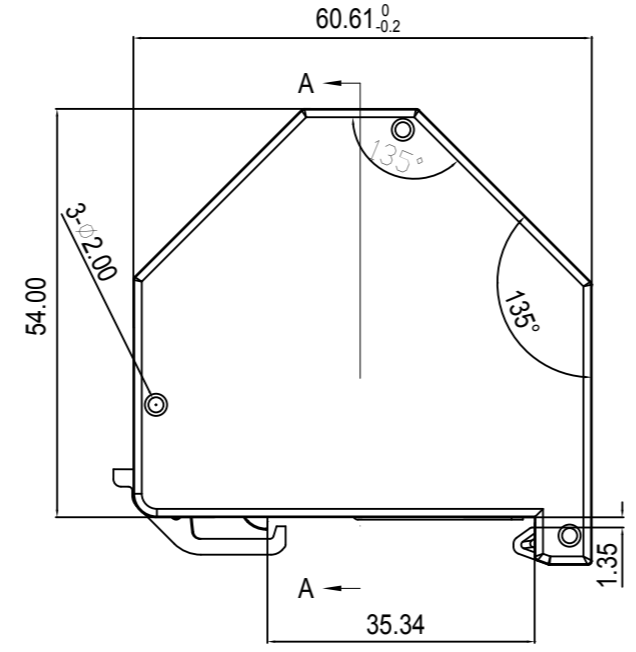
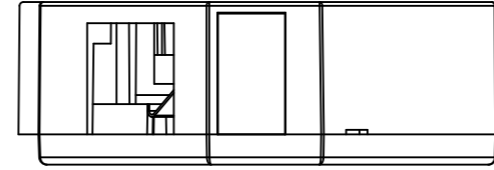

MECHANICAL
 1-Plastic Materials: PC FR V2
 2-Sheet Metal: Phosphor Bronze (electroplating Ni)
 3-Slide:AS

MODEL: ET-25186.V2	TITLE: Din Rail Module Holder					
DRAWN: ZhouGao	PART NO.			UNIT	MM	
DESIGNED:	MATERIAL			SCALE	1:1	
CHECKED:	FINISH			SHEET	1 OF 1	
	TOOLING NO.			SIZE	A4	REV.
APPROVED:	DWG NO.					