

TOP VIEW

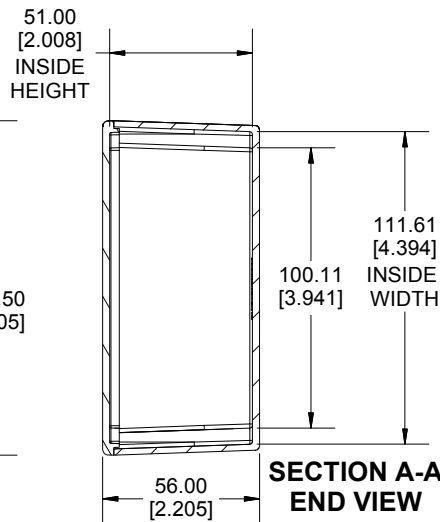

SECTION A-A
END VIEW

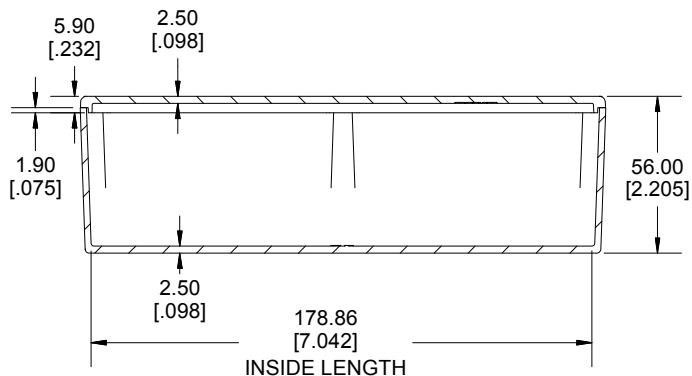

SECTION B-B
SIDE VIEW

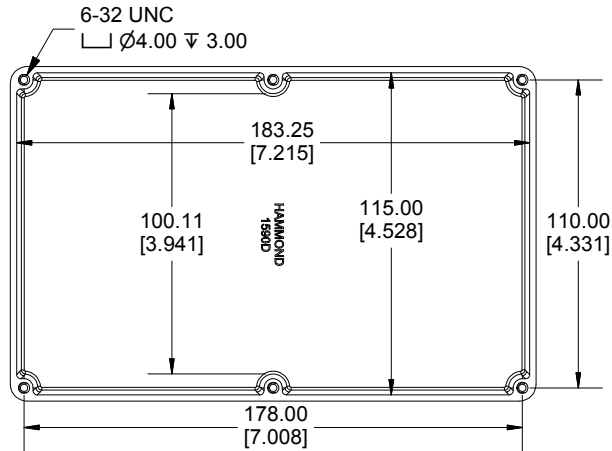

INSIDE BOX

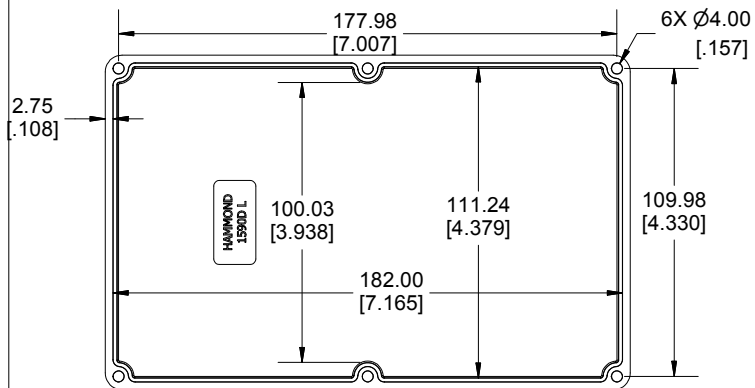

INSIDE LID

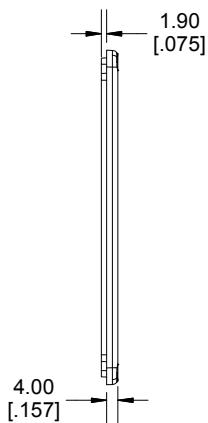

Enclosures can be Factory Modified (Milling, Drilling, Printing etc.)
Contact Factory (modshop@hammondmfg.com) for quotes
Solid models of this enclosure available in STEP or IGES.
(Part number and text placement/orientation on our products are subject to change,
we do not recommend using them as a locating reference for modification purposes)

NOTE

Purchased assembly includes box, lid and 6 cover screws.
Box and lid are made from Diecast Aluminum Alloy.
Silicone Gasket supplied with liquid resistant enclosure.

Recommended Torque: 50-55 cN.m [71-78 ozf.in]

Recommended Torque with Gasket : 25-30 cN.m [36-43 ozf.in]

PART NUMBERS

1590D Enclosure	
Natural Finish Enclosure	1590D
Black Textured Enclosure	1590DBK
1590D Liquid Resistant Enclosure (Silicone Gasket)	
Natural Finish Enclosure	1590WD
Black Textured Enclosure	1590WDBK

ACCESSORIES

Liquid Resistant Cover Screws

Stainless Steel Cover Screws (Pkg 100) [6-32 x 1/2" With O-Ring]	1590WMS100
Black Stainless Steel Cover Screws (Pkg 100) [6-32 x 1/2" With O-Ring]	1590WMS100BK

Standard Cover Screws

Plated Cover Screws (Pkg 100) [6-32 x 1/2"]	1590MS100
Black Cover Screws (Pkg 100) [6-32 x 1/2"]	1590MS100BK

**HAMMOND
MANUFACTURING®**

1590D

www.hammondmfg.com

Dimensions:
mm
[inches]