

Makeblock
Construct Your Dreams

mBot

ONE ROBOT PER CHILD

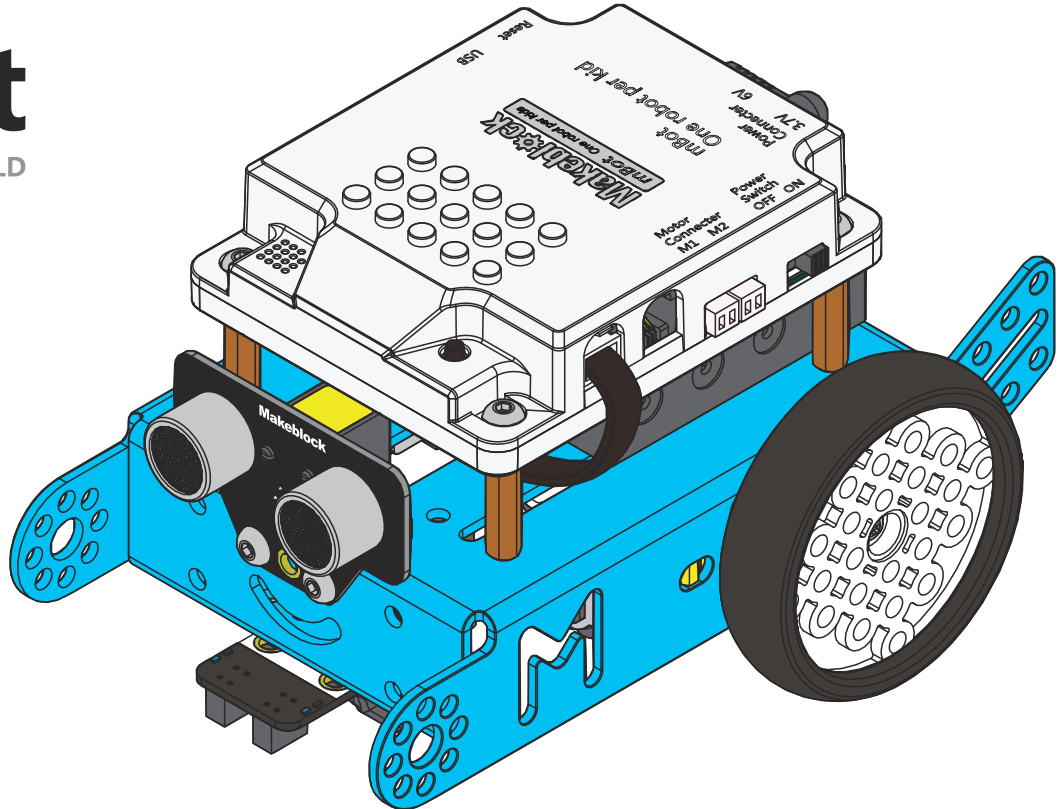

The pictures are for reference only, please make the object as standard.

Contents

Children should be accompanied by adults.

mBot is an educational robot for beginners to learn STEM (Science, Technology, Engineering, Mathematics) and experience the charms of mechanics, electronics, control systems and computer science.

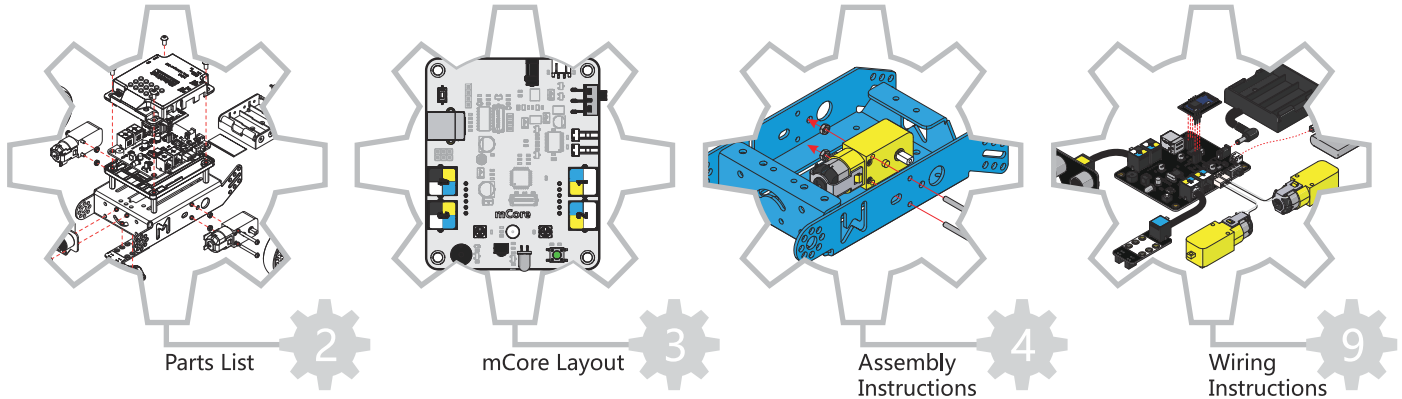

Warning: This product contains small parts and is intended for children at least 8 years old.

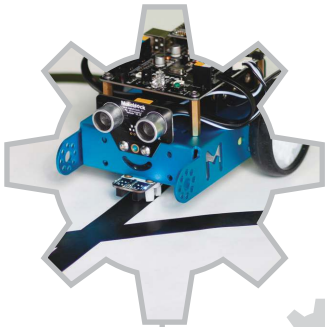

Get Started Playing

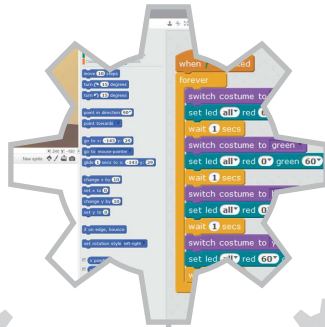

Graphical Programming

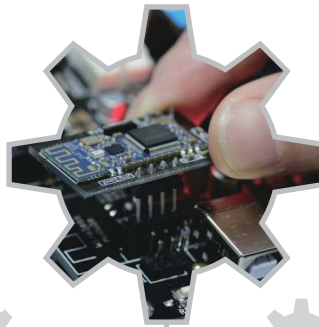

Wireless Communication

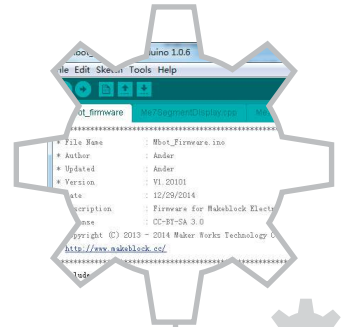

Arduino Programming (C Language)



Parts List

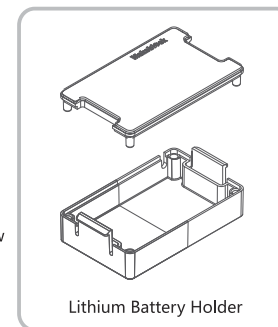
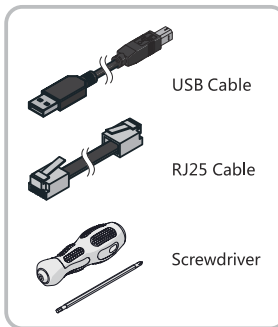
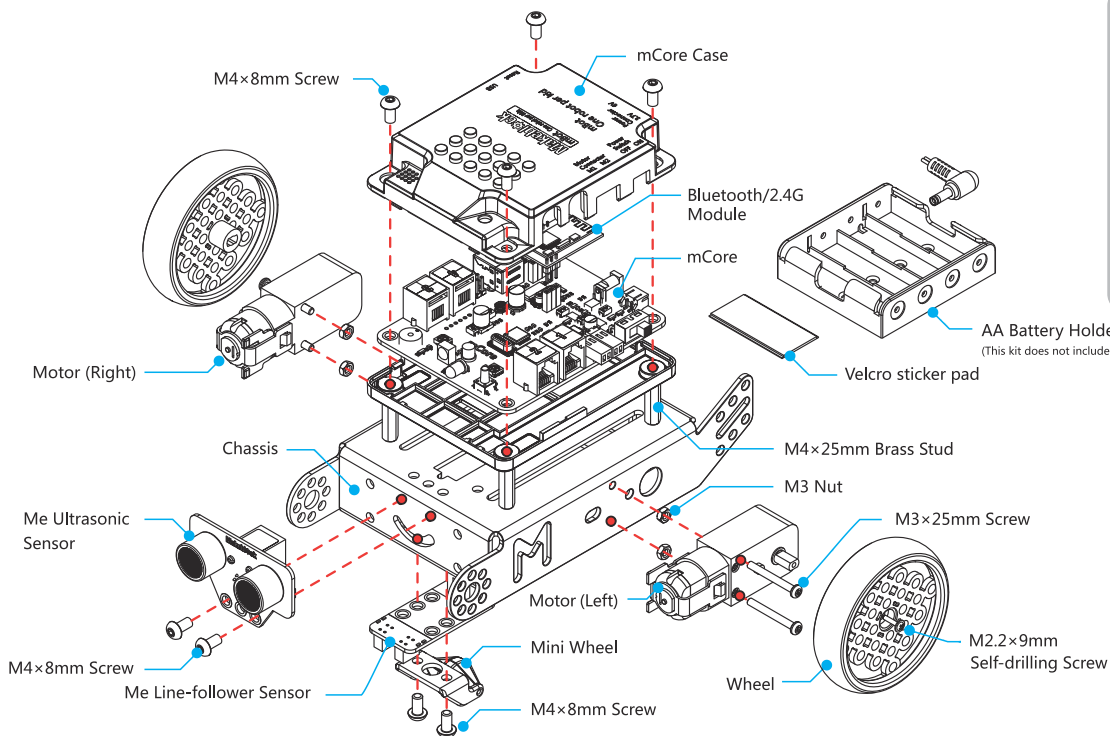

mCore Layout

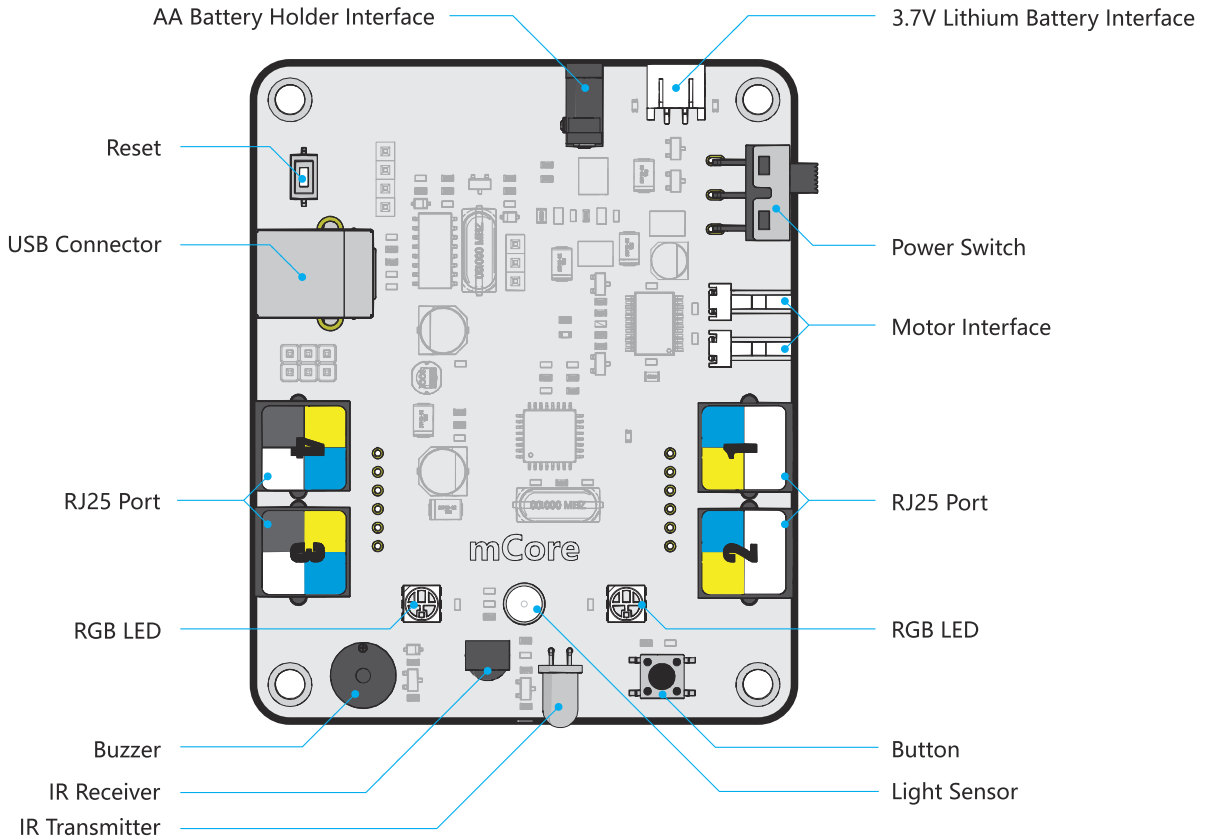

Assembly Instructions

- Chassis ×1
- Motor (Right) ×1
- M3 Nut ×2
- M3×25mm Screw ×2

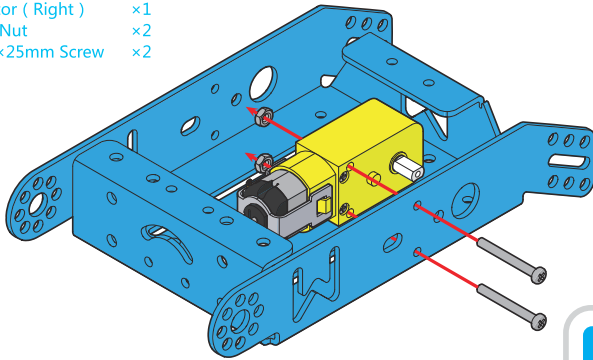

- Motor (Left) ×1
- M3 Nut ×2
- M3×25mm Screw ×2

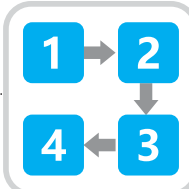
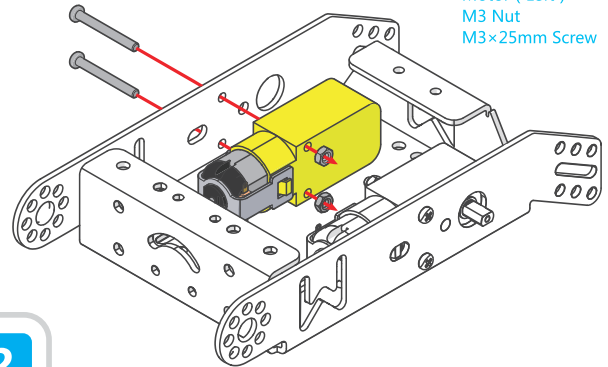

- M2.2×9mm Self-drilling Screw ×2

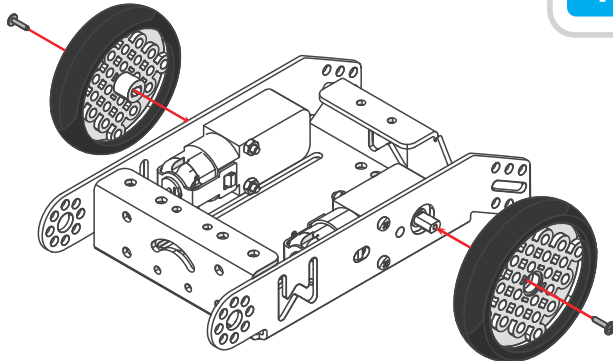

- Wheel ×2

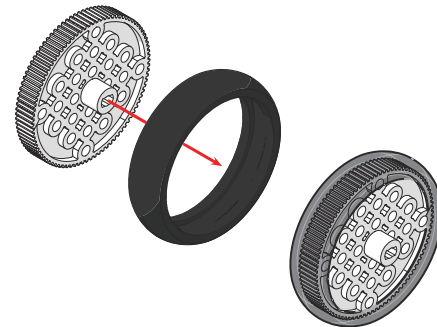

M4×8mm Screw ×2
Mini Wheel ×1
Me Line-follower Sensor ×1

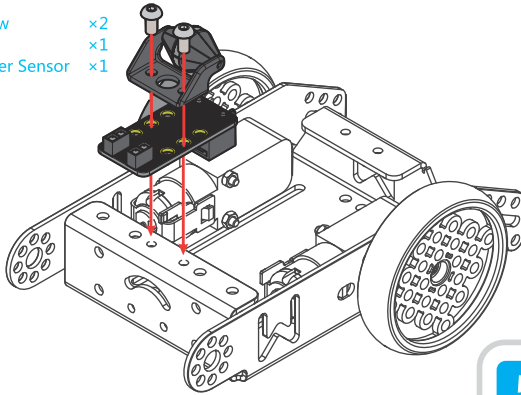

M4×8mm Screw ×2
Me Ultrasonic Sensor ×1

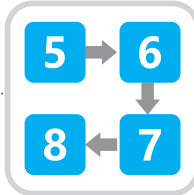
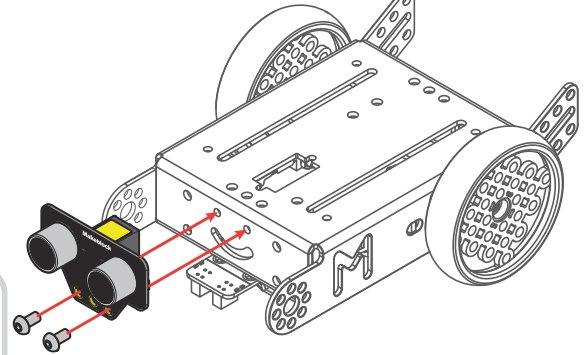

Tips:

After assembly, make sure to take out all the wires through here.

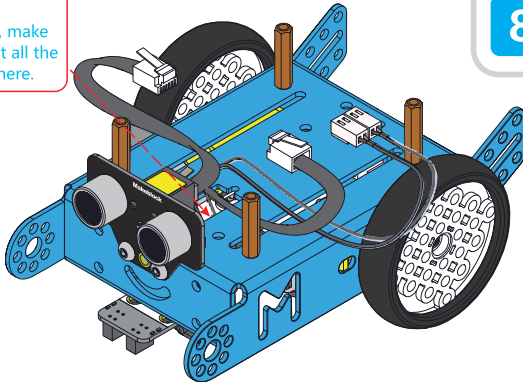

M4×25mm Brass Stud ×4

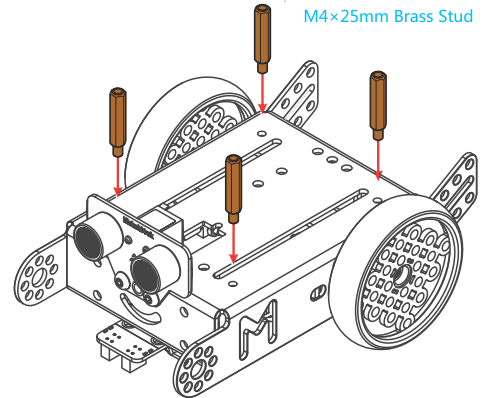

mCore Case
mCore

×1
×1

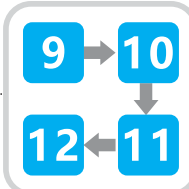
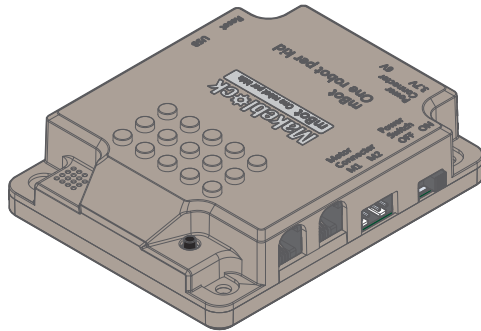
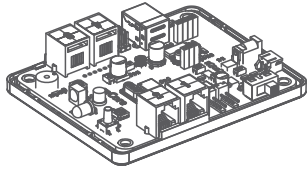
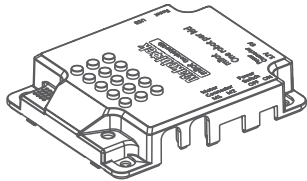

Bluetooth/2.4G Module ×1

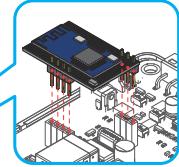
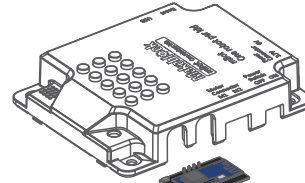

Tips:
Please check carefully if the pins of the Bluetooth or 2.4G Module are well inserted, otherwise the chip may be damaged upon power-on.

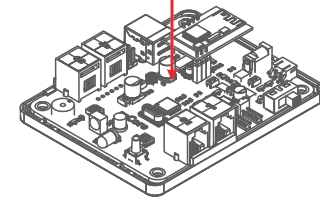
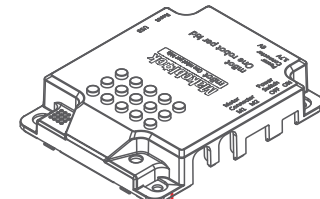

Powered by Lithium Battery (we provide two alternative power supply methods, Lithium battery or AA battery.)

Lithium Battery Holder ×1

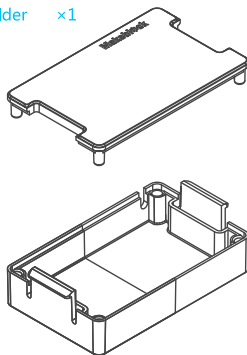

Tips:
If you use AA battery holder, please skip step 13, 14, 15, and 16.

3.7V Lithium Battery (Not included)

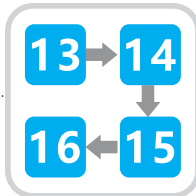
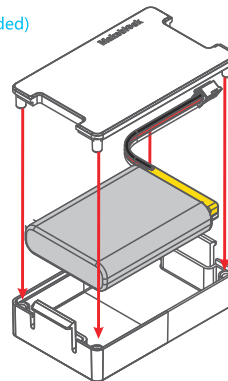

M4×8mm Screw ×4

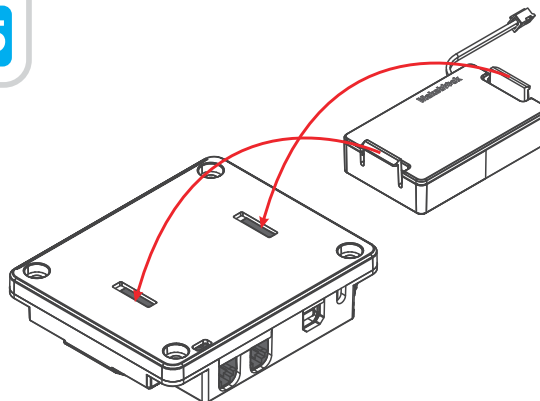
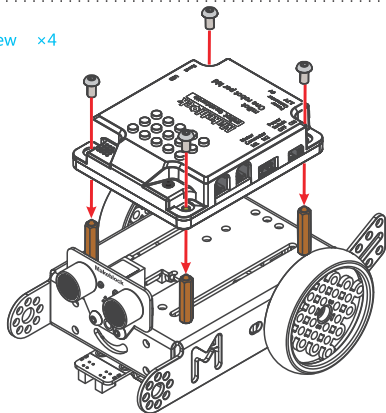

Powered by AA Battery (we provide two alternative power supply methods, Lithium battery or AA battery.)

- AA Battery Holder ×1
- Velcro sticker pad ×1

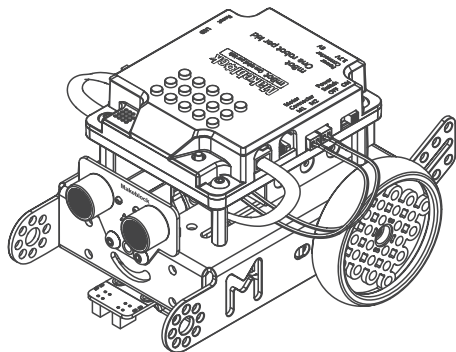
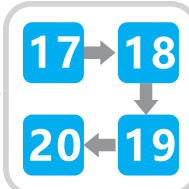
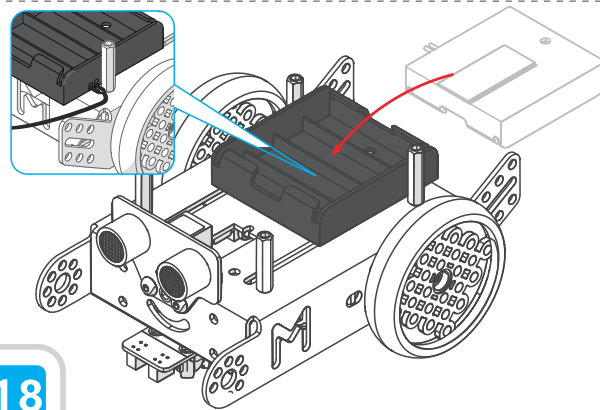
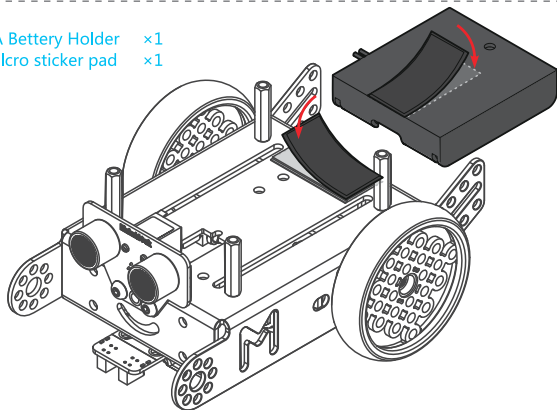

Please wire the electronic modules after assembly.

M4×8mm Screw ×4

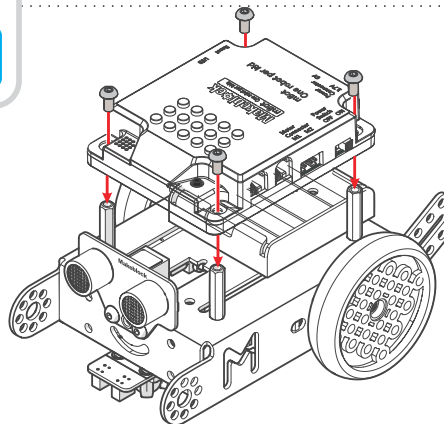

Wiring Instructions

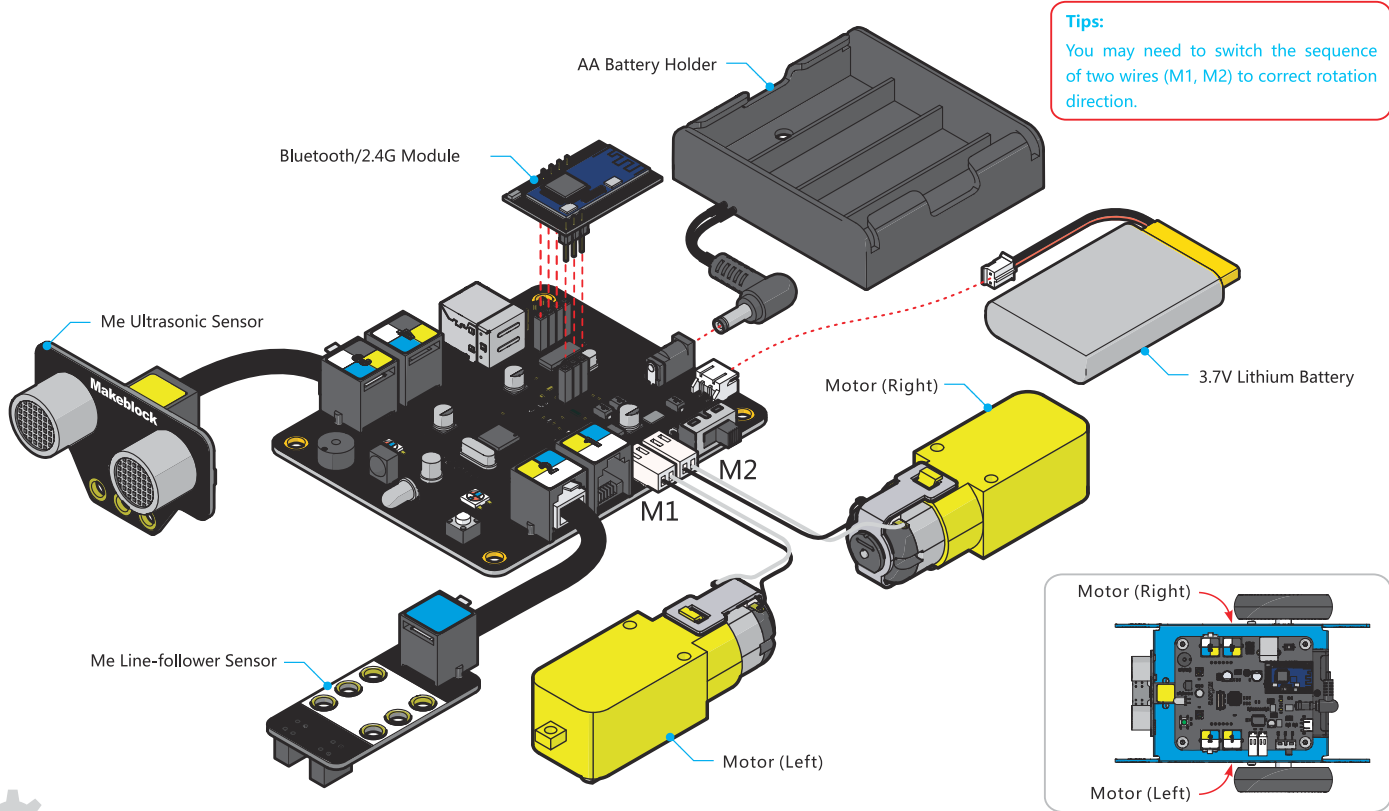

Batteries Suggestion

mCore Voltage Range: 3.7V DC-6V DC. There are two options for the power supply:

Option 1:

4×AA Batteries (Not included)



Option 2:

3.7V Lithium Battery (not included)
with standard 2.0 interface. It supports
on-board USB charging.



Get Started Playing

Now it's time to test your mBot.

mBot has 3 pre-set modes: **IR control mode**, **obstacle avoidance mode** and **line-following mode**.

When you turn on your mBot for the first time, it will be in IR control mode by default and the on-board RGB LED is white. Now you can use the IR remote control to start controlling mBot. In addition, you can also download APP to control the Bluetooth version mBot.

Without an IR remote control or an app, you can still test your mBot by pressing the on-board push button to change modes:

- When the RGB LED is green, mBot is in the obstacle avoidance mode. Place your mBot on the floor, and watch it avoid obstacles.
- When the RGB LED is blue, mBot is in the line-following mode. Place your mBot on the line-follower map and watch it track the line.

Tips: We offer you IR remote control as a gift. It is suggested to play mBot on the flat ground for trial.

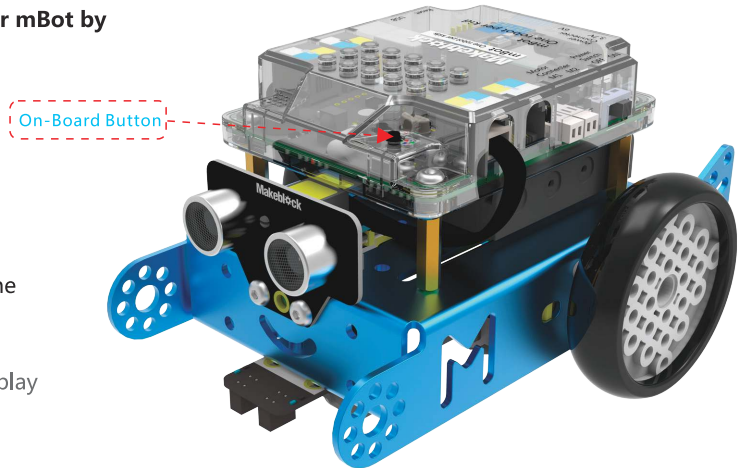

IR Remote Control (Quick Start Guide)

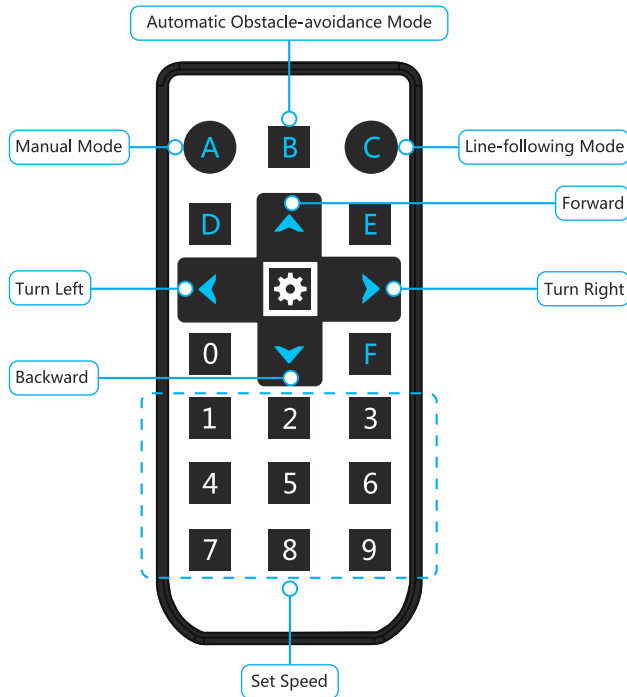

Tips: If the speed you set is too low, mBot may not move. In this case, just set higher speed.

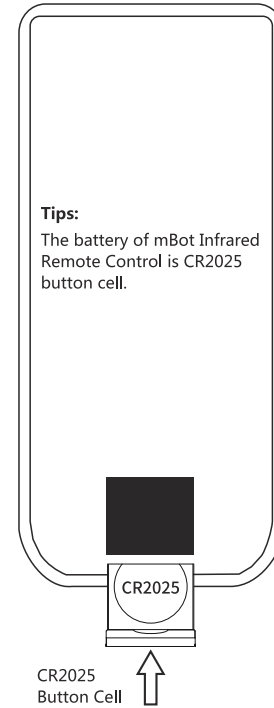

Graphical Programming

1. Introduction to mBlock

mBlock is a graphical programming tool based on Scratch 2.0. It allows users to read sensor values, control the output of hardware modules and quickly get started programming mBot.

Quick Guide for mBlock:

<http://learn.makeblock.com/mbot-get-started/>

Download:

<http://learn.makeblock.com/mbot-resource-download/>

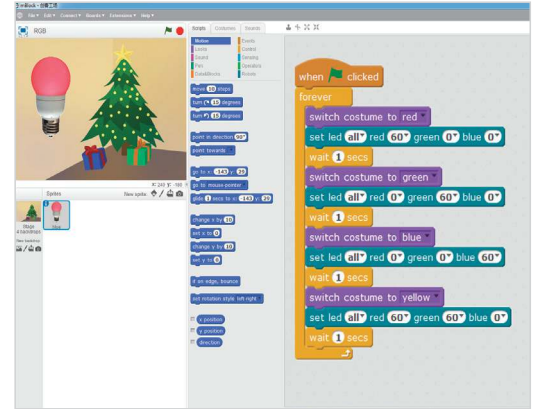

2. Introduction to mBlockly

mBlockly is a graphical programming tool designed for iPad users. With mBlockly, you can easily realize many interesting interactions.

Download:

Search "mBlockly" in App Store and download it now!

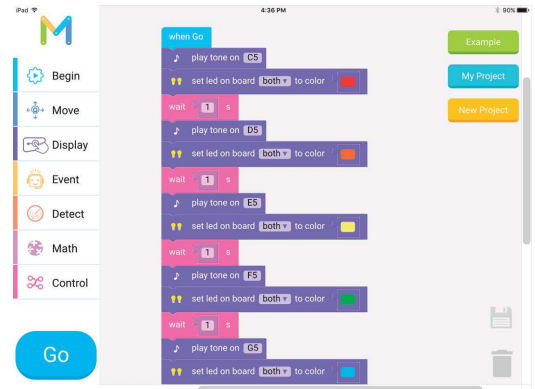

Wireless Communication

1. Introduction to Bluetooth Module

The Bluetooth module is designed specially for mCore with the support of Bluetooth 2.0 and 4.0. It is suitable for both individual users and family. It can be matched with Android or iOS smartphone to control mBot, and also can be matched with computers (that support Bluetooth communications) to do wireless programming.

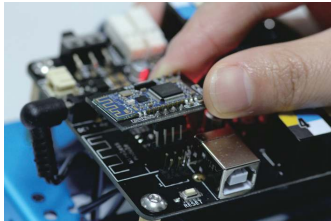

More detailed tutorials:
<http://learn.makeblock.com/get-started/>

2. Introduction to 2.4G Module

The 2.4G module includes two parts: the 2.4G wireless serial-USB for computers, and the 2.4G wireless serial-module for mCore. It uses the same technology as the wireless mouse and is very suitable for the classroom. No driver and pairing is needed.

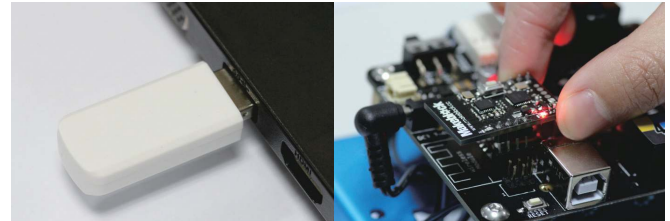

More detailed tutorials:
<http://learn.makeblock.com/get-started/>

Arduino Programming (C Language)

mBot also supports Arduino C. Arduino is an open-source electronics prototyping platform based on flexible, easy-to-use hardware and software.

The Arduino software consists of a development environment (IDE) and the core libraries.

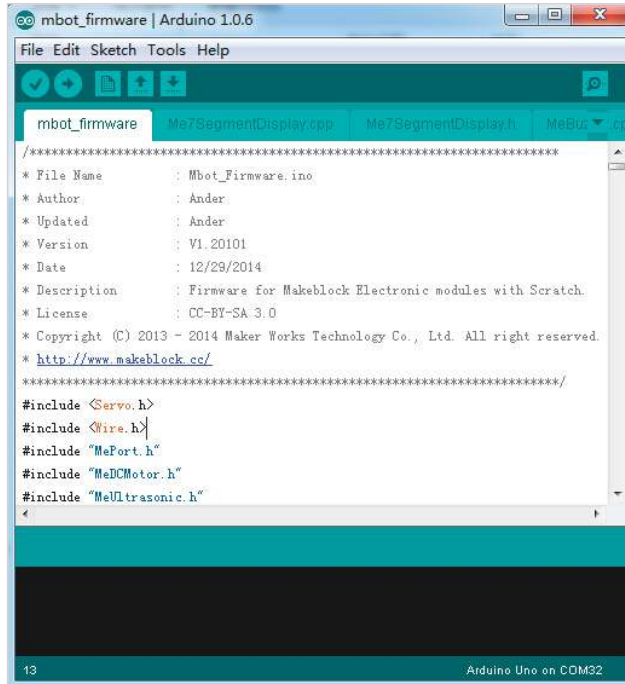

```
Arduino IDE window showing the mbot_firmware.ino file. The code includes metadata and library includes.
```



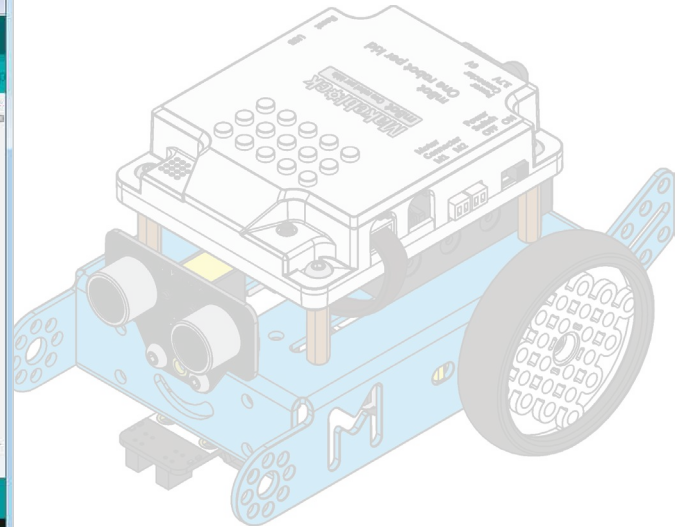





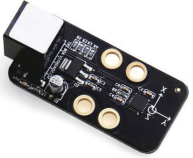
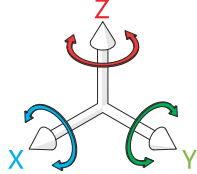

```
*****  
* File Name      : Mbot_Firmware.ino  
* Author        : Ander  
* Updated       : Ander  
* Version       : V1.20101  
* Date          : 12/29/2014  
* Description    : Firmware for Makeblock Electronic modules with Scratch.  
* License       : CC-BY-SA 3.0  
* Copyright (C) 2013 - 2014 Maker Works Technology Co., Ltd. All right reserved.  
* http://www.makeblock.cc/  
*****/  
#include <Servo.h>  
#include <Wire.h>  
#include "MePort.h"  
#include "MeDCMotor.h"  
#include "MeUltrasonic.h"
```

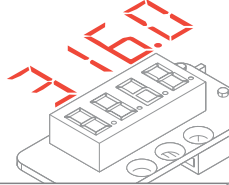

For more information, please visit:

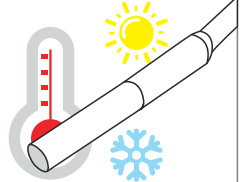
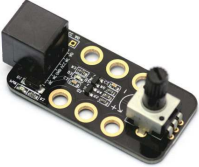
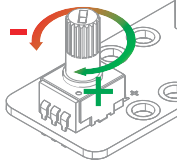
<http://learn.makeblock.com/mbot-programming/>

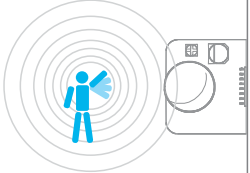
Electronic Modules on Makeblock--Further Exploration

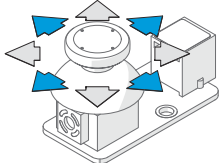
	<p>Me 3-Axis Accelerometer and Gyro Sensor measure movement and position – useful for detecting bumps for sumo robots.</p>			<p>Me Sound Sensor measures volume. It could be used in a project that uses a voice operated switch.</p>	
	<p>Me 7-segment Serial Display allows information such as time, speed or scores to be displayed.</p>			<p>Me Temperature Sensor Module measures temperature, ranging from -55°C to 125°C.</p>	
	<p>Me Potentiometer senses rotation – this information could then be used to control the speed of a robot, the brightness of a light, or anything else you could imagine.</p>			<p>Me Passive IR Detector Module detects infrared signals from humans or animals within 6 meters.</p>	
	<p>Me Joystick can control the movement of a robot or a part of a robot.</p>		<p>For more information, please visit www.makeblock.com.</p>		

mBot Add-On Pack--Six-legged Robot

Six-legged robot is a 3-in-1 expansion pack based on mBot. You can construct "Beetle", "Mantis" and "Crazy Frog" with mBot and the parts inside the pack.

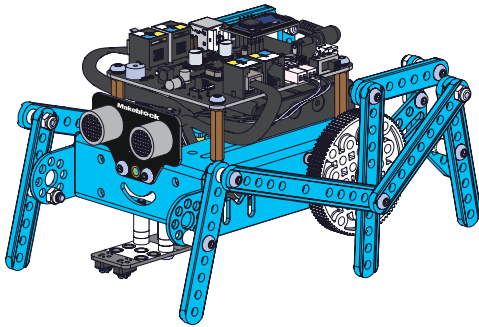

Beetle

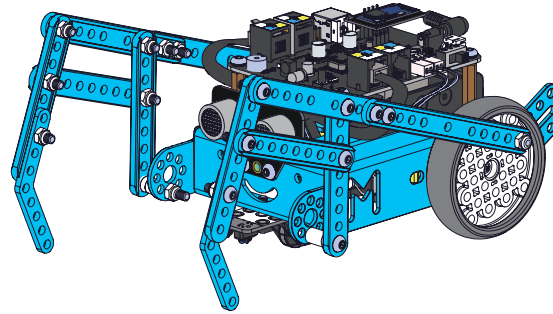

Mantis

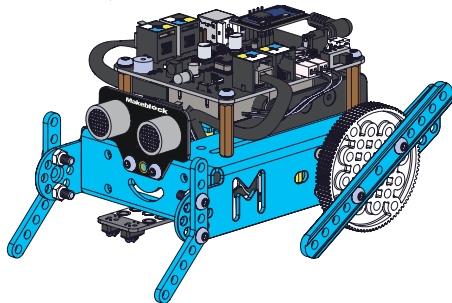

Crazy Frog

For more information, please visit www.makeblock.com.

mBot Add-On Pack--mBot Servo Pack

mBot servo pack is a 3-in-1 expansion pack based on mBot. You can construct "Dancing Cat", "Head-Shaking Cat" and "Light-Emitting Cat" with mBot and the parts inside the pack.

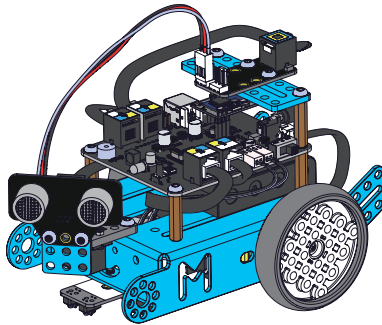

Head-Shaking Cat

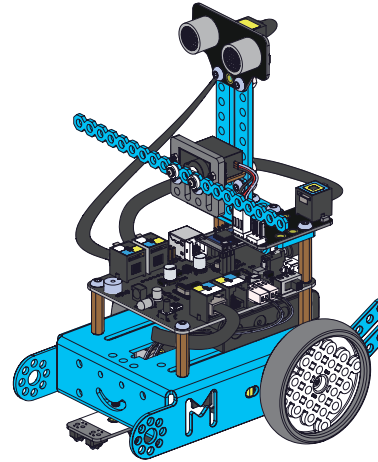

Dancing Cat

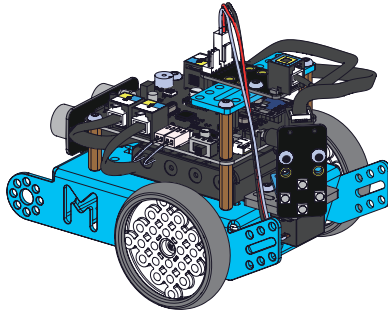

Light-Emitting Cat

For more information, please visit www.makeblock.com.



FCC Information

This device complies with part 15 of the FCC Rules. Operation is subject to the following two conditions: (1) This device may not cause harmful interference, and (2) this device must accept any interference received, including interference that may cause undesired operation. Changes or modifications not expressly approved by the party responsible for compliance could void the user's authority to operate the equipment.

NOTE: This equipment has been tested and found to comply with the limits for a Class B digital device, pursuant to Part 15 of the FCC Rules. These limits are designed to provide reasonable protection against harmful interference in a residential installation. This equipment generates, uses and can radiate radio frequency energy and, if not installed and used in accordance with the instructions, may cause harmful interference to radio communications. However, there is no guarantee that interference will not occur in a particular installation. If this equipment does cause harmful interference to radio or television reception, which can be determined by turning the equipment off and on, the user is encouraged to try to correct the interference by one or more of the following measures:

- Reorient or relocate the receiving antenna.
- Increase the separation between the equipment and receiver.
- Connect the equipment into an outlet on a circuit different from that to which the receiver is connected.
- Consult the dealer or an experienced radio/TV technician for help.

This modular complies with FCC RF radiation exposure limits set forth for an uncontrolled environment. This transmitter must not be co-located or operating in conjunction with any other antenna or transmitter.

If the FCC identification number is not visible when the module is installed inside another device, then the outside of the device into which the module is installed must also display a label referring to the enclosed module. This exterior label can use wording such as the following: "Contains Transmitter Module FCC ID: 2ACWW1300133B Or Contains FCC ID: 2ACWW1300133B Or Contains FCC ID: 2ACWW1300303M Or Contains FCC ID: 2ACWW1300303U"

when the module is installed inside another device, the user manual of this device must contain below warning statements;

1. This device complies with Part 15 of the FCC Rules. Operation is subject to the following two conditions:

- (1) This device may not cause harmful interference.
 - (2) This device must accept any interference received, including interference that may cause undesired operation.
2. Changes or modifications not expressly approved by the party responsible for

compliance could void the user's authority to operate the equipment. The devices must be installed and used in strict accordance with the manufacturer's instructions as described in the user documentation that comes with the product.

Product	mBot
---------	------



Limited Warranty

This product is warranted against defects in materials and workmanship under normal use by the original purchaser for 90 days after the date of purchase from an authorized retailer.

THERE ARE NO OTHER EXPRESS WARRANTIES.

This warranty does not cover: (a) damage or failure caused by or attributable to abuse, misuse, failure to follow instructions, improper installation or maintenance, alteration, accident, Acts of God (such as floods or lightning), or excess voltage or current; (b) improper or incorrectly performed repairs by non-authorized service facilities; (c) consumables such as fuses or batteries; (d) ordinary wear and tear or cosmetic damage; (e) transportation, shipping or insurance costs; (f) costs of product removal, installation, set-up service, adjustment or reinstallation; and (g) claims by persons other than the original purchaser.

Should a problem occur that is covered by this warranty, take the product and the original sales receipt as proof of purchase date to the place of purchase. The product, at the warrantor's option, unless otherwise provided by law: (a) be repaired without charge for parts and labor; (b) be replaced with the same or a comparable product; or (c) a refund of the purchase price will be provided. All replaced parts and products, and products on which a refund is made, become the property of the warrantor. New or reconditioned parts and products may be used in the performance of warranty service. Repaired or replaced parts and products are warranted for the remainder of the original warranty period. You will be charged for repair or replacement of the product made after the expiration of the warranty period.

ALL IMPLIED WARRANTIES, INCLUDING THE IMPLIED WARRANTY OF MERCHANTABILITY AND, IF APPLICABLE, THE IMPLIED WARRANTY OF FITNESS FOR A PARTICULAR PURPOSE, SHALL EXPIRE ON THE EXPIRATION OF THE STATED WARRANTY PERIOD.

EXCEPT AS DESCRIBED ABOVE, THE WARRANTOR SHALL HAVE NO LIABILITY OR RESPONSIBILITY TO THE PURCHASER OF THE PRODUCT OR ANY OTHER PERSON OR ENTITY WITH RESPECT TO ANY LIABILITY, LOSS OR DAMAGE CAUSED DIRECTLY OR INDIRECTLY BY USE OR PERFORMANCE OF THE PRODUCT OR ARISING OUT OF ANY BREACH OF THIS WARRANTY, INCLUDING, BUT NOT LIMITED TO, ANY DAMAGES RESULTING FROM INCONVENIENCE AND ANY LOSS OF TIME, DATA, PROPERTY, REVENUE, OR PROFIT AND ANY INDIRECT, SPECIAL, INCIDENTAL, OR CONSEQUENTIAL DAMAGES, EVEN IF THE WARRANTOR HAS BEEN ADVISED OF THE POSSIBILITY OF SUCH DAMAGES. BEEN ADVISED OF THE POSSIBILITY OF SUCH DAMAGES.

Warnings

- Adult supervision and assistance are required.
- CHOKING HAZARD — This product contains small parts and functional sharp points on components. Keep away from children under age 3.
- Read and follow all instructions in the user's guide before use.
- Retain this user's guide for future reference.

Battery Notes

- Use only fresh batteries of the required size and type. Do not mix old and new batteries, different types of batteries (standard, alkaline, or rechargeable), or rechargeable batteries of different capacities.
- Dispose of batteries promptly and properly. Do not burn or bury them.
- If you do not plan to play with the robot for an extended period of time, remove the batteries.

Caution

- Do not insert the wires into telecommunication or network socket outlets.
- As an extra precaution, check this product regularly for signs of wear or damage.
- Ensure all wiring connections are correct before inserting batteries and switching on the product. Failure to do so may result in damage to components and the product.
- Ensure all wires are correctly connected to the battery terminals and other connectors. If the circuit does not work, make sure the plastic insulation of the wire is not obstructing the connection to the connector.
- When you have finished playing, remove the batteries and switch off the unit before you disconnect the wires. Do not apply any components or parts to the unit other than those provided with this kit.
- To prevent overheating and damage, do not short-circuit the battery terminals and connectors. Do not block or cover the motor or other moving parts.

This equipment complies with FCC RF radiation exposure limits set forth for an uncontrolled environment.

This equipment should be installed and operated with a minimum distance of 20 centimeters between the radiator and your body.

You may contact the warrantor at: support@makeblock.com



Makeblock Co., Ltd.

Technical Support: tec-support@makeblock.com
www.makeblock.com



: @Makeblock



: @Makeblock



: +Makeblock