



TELEDYNE  
RELAYS  
A Unit of Teledyne Electronics and Communications

## COMMERCIAL TO-5 RELAYS DPDT MAGNETIC LATCHING

# SERIES 722

SERIES DESIGNATION	RELAY TYPE
722	DPDT basic relay
722D	DPDT relay with internal diode for coil transient suppression

### DESCRIPTION

The magnetic-latching TO-5 relay, originally conceived and developed by Teledyne, has become one of the industry standards for low-level switching from dry circuit to 1 ampere. Designed for high-density PC board mounting, the 722 relay has become one of the most versatile ultraminiature relays available because of its small size and low coil power dissipation.

Unique construction features and manufacturing techniques provide excellent resistance to environmental extremes and overall high reliability.

- All welded construction.
- Unique uni-frame design providing high magnetic efficiency and mechanical rigidity.
- High force/mass ratios for resistance to shock and vibration.
- Advanced cleaning techniques provide maximum assurance of internal cleanliness.
- Precious metal alloy contact material with gold plating assures excellent high current and dry circuit switching capabilities.

The Series 722D relay has discrete silicon diodes for coil transient suppression.

The Series 722 magnetic-latching relays are ideally suited for applications where coil power dissipation must be minimized. The relays can be operated with a short duration pulse and after the contacts have transferred, no external coil power is required. The magnetic-latching feature of the Series 722 provides a “memory” capability, since the relays will not reset upon removal of coil power.

By virtue of its inherently low intercontact capacitance and contact circuit losses, the 722 relay has proven to be an excellent ultraminiature RF switch for frequency ranges well into the UHF spectrum. A typical RF application for the TO-5 relay is in handheld radio transceivers, wherein the combined features of good RF performance, small size, low coil power dissipation and high reliability make it a preferred method of Transmitter-Receive switching (see Figure 1).

### PRINCIPLE OF OPERATION

Energizing Coil B produces a magnetic field opposing the holding flux of the permanent magnet in Circuit B. As this net holding force decreases, the attractive force in the air gap of Circuit A, which also results from the flux of the permanent magnet, becomes great enough to break the armature free of Core B, and snap it into a closed position against Core A. The armature then remains in this position upon removal of power from Coil B, but will snap back into position B upon energizing Coil A. Since operation depends upon cancellation of a magnetic field, it is necessary to apply the correct polarity to the relay coils as indicated on the relay schematic. When latching relays are installed in equipment, the latch and reset coils should not be pulsed simultaneously. Coils should not be pulsed with less than rated coil voltage and the pulse width should be a minimum of three times the specified operate time of the relay. If these conditions are not followed, it is possible for the relay to be in the magnetically neutral position.

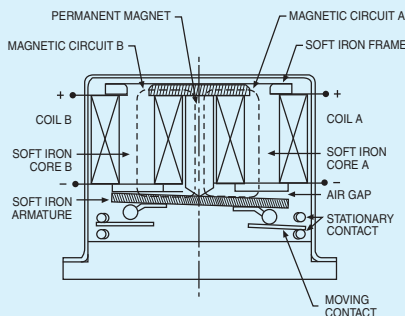

### ENVIRONMENTAL AND PHYSICAL SPECIFICATIONS

Temperature (Ambient)	Storage	-65°C to +125°C
	Operating	-55°C to +85°C
Vibration (General Note 1)		10 g's to 500 Hz
Shock (General Note 1)		30 g's, 6 msec, half-sine
Enclosure		Hermetically sealed
Weight		0.1 oz. (2.9g) max.

**SERIES 722**

**GENERAL ELECTRICAL SPECIFICATIONS (@25°C) (Notes 2 & 3)**

<b>Contact Arrangement</b>	2 Form C (DPDT)
<b>Rated Duty</b>	Continuous
<b>Contact Resistance</b>	0.15 ohm max. before life; 0.25 ohm max. after life at 1A/28Vdc (measured 1/8" from header)
<b>Contact Load Ratings (DC)</b> (See Fig. 2 for other DC resistive voltage/current ratings)	Resistive: 1 Amp/28Vdc Inductive: 200 mA/28Vdc (320 mH) Lamp: 100 mA/28Vdc Low Level: 10 to 50 $\mu$ A/10 to 50mV
<b>Contact Load Ratings (AC)</b>	Resistive: 250 mA/115Vac, 60 and 400 Hz (Case not grounded) 100 mA/115Vac, 60 and 400 Hz (Case grounded)
<b>Contact Life Ratings</b>	10,000,000 cycles (typical) at low level 1,000,000 cycles (typical) at 0.5A/28Vdc resistive 100,000 cycles min. at all other loads specified above
<b>Contact Overload Rating</b>	2A/28Vdc Resistive (100 cycles min.)
<b>Contact Carry Rating</b>	Contact factory
<b>Coil Operating Power</b>	290 milliwatts typical at nominal rated voltage
<b>Operate Time</b>	2.0 ms max at nominal rated coil voltage
<b>Minimum Operate Pulse</b>	6.0 ms width @ rated voltage
<b>Intercontact Capacitance</b>	0.4 pf typical
<b>Insulation Resistance</b>	1,000 megohms min. between mutually isolated terminals
<b>Dielectric Strength</b>	Atmospheric pressure: 350 Vrms/60Hz
<b>Negative Coil Transient 722D</b>	2.0 Vdc Max.
<b>Diode P.I.V. 722D</b>	60 Vdc Min.

**DETAILED ELECTRICAL SPECIFICATIONS (@25°C) (Note 3)**

BASE PART NUMBERS (See Note 6 for full P/N example)		➔					
		722-5 722D-5	722-6 722D-6	722-9 722D-9	722-12 722D-12	722-18 722D-18	722-26 722D-26
<b>Coil Voltage (Vdc)</b>	Nom.	5.0	6.0	9.0	12.0	18.0	26.5
	Max.	6.0	8.0	12.0	16.0	24.0	32.0
<b>Coil Resistance (Ohms <math>\pm</math>20% @25°C)</b>		61	120	280	500	1130	2000
<b>Set &amp; Reset Voltage (Vdc, Max.) Pulse Operated</b>		3.5	4.5	6.8	9.0	13.5	18.0

**PERFORMANCE CURVES (Note 2)**

TYPICAL RF PERFORMANCE

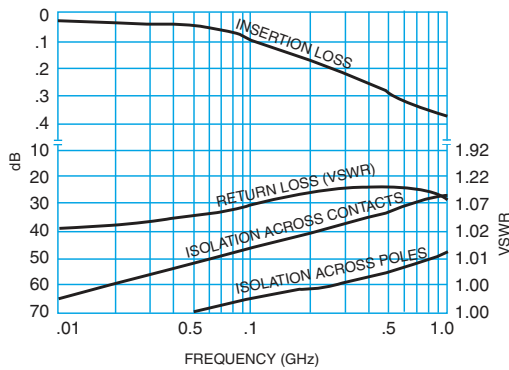

**FIGURE 1**

TYPICAL DC CONTACT RATING (RESISTIVE)

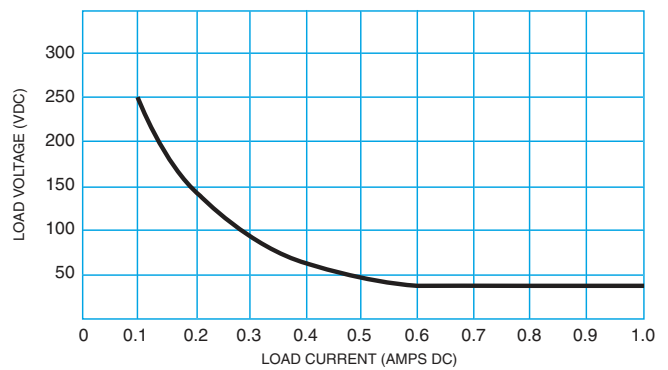
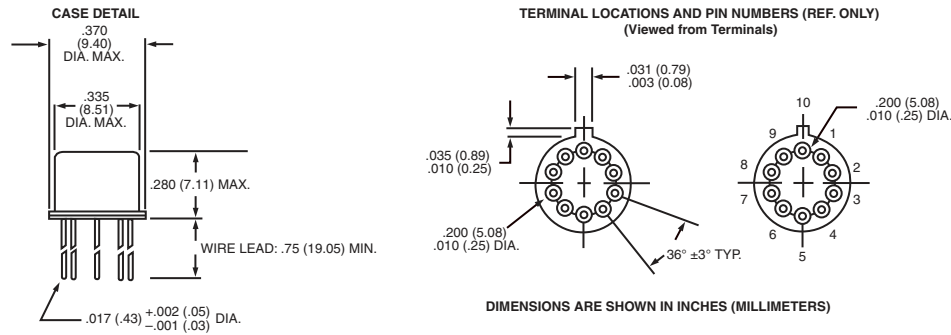

**FIGURE 2**

CENTIGRID® AND 70-5

# SERIES 722

## OUTLINE DIMENSIONS



## SCHEMATIC DIAGRAM

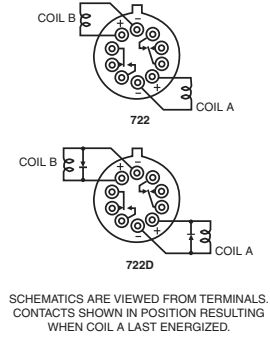

## GENERAL NOTES

1. Relay contacts will exhibit no chatter in excess of 10  $\mu$ sec or transfer in excess of 1  $\mu$ sec.
2. "Typical" characteristics are based on available data and are best estimates. No on-going verification tests are performed.
3. Unless otherwise specified, parameters are initial values.
4. Unless otherwise specified, relays will be supplied with either gold-plated or solder-coated leads.
5. The slash and characters appearing after the slash are not marked on the relay.
- 6.

### Teledyne Part Numbering System for Commercial Relays

