

Top View of Assembly

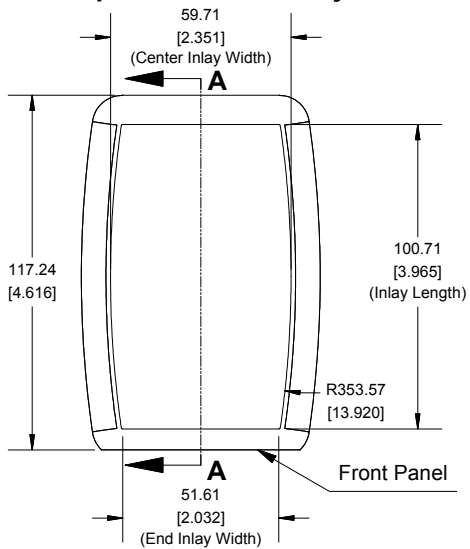

SECTION A-A (Side View Inside Assembly)

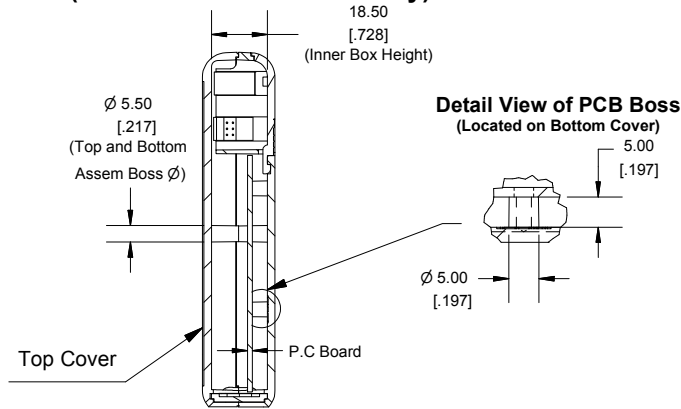

End View of Assembly

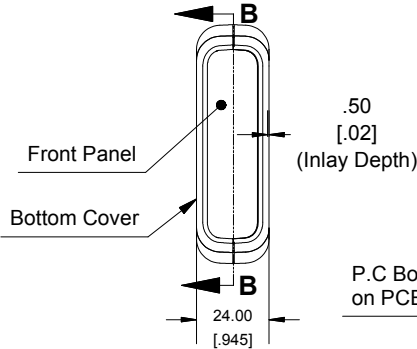

SECTION B-B (Inside of Bottom Cover)

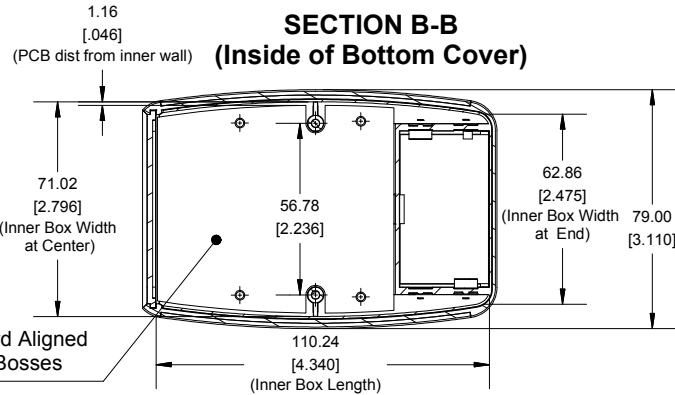

Maximum P.C. Board Size

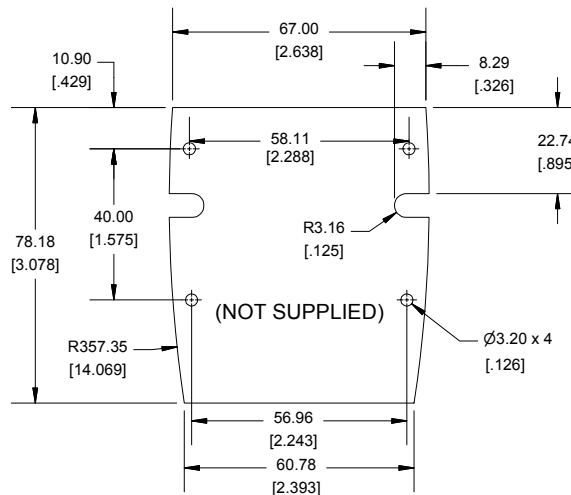

Front Panel

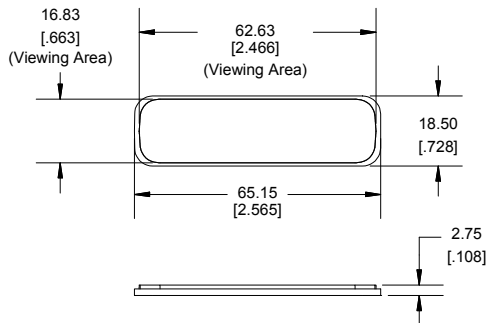

Enclosures can be Factory Modified (Milling, Drilling, Printing etc.)
 Contact Factory mjm@hammondmfg.com for quotes
 Solid models of this enclosure available in STEP or IGES.
 (Part number and text placement/orientation on our products are subject to change,
 we do not recommend using them as a locating reference for modification purposes)

NOTE

Enclosure molded from GP ABS Plastic.
 Purchased assembly includes Top, Bottom, front plastic panel, Battery Door, battery spring clips (4 pcs), 9V adapter (1pcs) and 2 cover screws.
 (P.C. Board not supplied)

Recommended Cover screw torque -- 2.5 lbf-in (30 cN-m)

PART NUMBER

1553B Battery Enclosure	
Black Enclosure/Grey Over-mold	1553BBKBAT
Grey Enclosure/Grey Over-mold	1553BGYBAT
Translucent Blue Enclosure/ Black Over-mold	1553BTBUBKBAT
Red Enclosure/ Black Over-mold	1553BRDBKBAT
Yellow Enclosure/ Black Over-mold	1553BYLBKBAT
Black Enclosure/ Black Over-mold	1553BBKBKBAT

ACCESSORIES

Oval Head Cover Screws Self-Tapping (Pkg 100) [#4 X 3/4" (19mm)]	1593QS100 (Silver) 1593QS100BK (Black)
P.C. Board Self Tapping Screw [#4 X 1/4" (6.4mm) Plated]	1593ATS50 (Pkg 50) 1593ATS100 (Pkg 100)
Belt or Pocket Clip	1599CLIP (Black) 1599CLIPGY (Grey)
9V Battery Kit	BS61
AA Battery Clip Kit (4 positive and 4 Negative)	1553HDR-BKIT

HAMMOND MANUFACTURING®
1553BBAT
www.hammondmfg.com

Dimensions:
 mm
 [inches]