

GP Batteries

Product Specifications

Model No.: GPZA675

Document Number: ZA0004

Revision:03

Page 1 of 5

1. APPLICABILITY

This specification is applicable to GP Zinc Air GPZA675.

2. GENERAL

2.1	Type designation	: PR44(IEC/JIS) / 7003ZD(ANSI)
2.2	Nominal voltage	: 1.4V
2.3	Shape and dimension	: Refer to Drawing 1.
2.4	Typical Capacity	: 620mAh (continuous discharge under 620Ω to 0.9V at 20°C)
2.5	Typical weight	: 1.8g
2.6	Warranty period	: 12 months
2.7	Date code	: Unless otherwise specified, every battery will carry an expiry date code for 36 months. (e.g. a battery manufactured on January 2009 will carry an expiry code of 01-12.)
2.8	Country of origin	: made in Germany

3. APPEARANCE

There shall be no dirt, scratch or deformation detrimental to practical service in appearance.

4. CELL VOLTAGE

4.1 Test method I

Method of sampling	: MIL-STD-105E level II single sampling normal inspection.
Voltmeter	: Digital Voltmeter (DVM) with the precision of 1mV (internal resistance not less than 1 Megohm)
Test temperature	: 20±2°C

4.2 Off Load Voltage

At shipping	12 months after manufactured
*1.36V to 1.46V	*1.36V to 1.46V

4.3 On Load Voltage

Initial	12 months after manufactured
*Above 1.3V	*Above 1.3V

Load resistance : 620Ω ± 0.5% (measure time : 0.8 seconds)

*Take away the tape on battery and wait for 15 minutes before measure Voltage.

GP Batteries

Product Specifications

Model No.:GPZA675

Document Number: ZA0004

Revision:03

Page 2 of 5

5. SERVICE OUTPUT

5.1 Test method

- (1) The resistance of external discharge circuit shall be as specified plus or minus 0.5%.
- (2) The duration of discharge time periods shall be as specified plus or minus 1%.
- (3) Storage shall be at $20\pm 2^{\circ}\text{C}$, $65\pm 20\%\text{RH}$ and discharge tests shall be at $20\pm 2^{\circ}\text{C}$, $65\pm 20\%\text{RH}$.

5.2 Service Life

	Test Mode	Application	Initial (Nominal)	Initial (Minimum)	12 months storage at 20°C (Nominal)
Service life at $20\pm 2^{\circ}\text{C}$	620Ω continuous (EPV=0.9V)	Reference test	247H	225H	153H

M: minute H: hour EPV: end point voltage

*The initial discharge test shall commence within 30 days of manufacture. During this period, the cells shall be stored under room temperature conditions. ($20\pm 2^{\circ}\text{C}$ and $65\pm 20\%$ relative humidity)

**Take away the tape on battery and wait for 15 minutes before measure Service Life.

6. ELECTROLYTE LEAKAGE

	Test Items	Test Conditions	Requirements
6.1	Arrival at warehouse	Within two months after shipping	There shall be no leakage observed with naked eye and no bulging or deformation of batteries in excess of dimensions on shown in the Drawing 1
6.2	Long term storage	Within storing for 12 months at $20 \pm 15^{\circ}\text{C}$, $65\pm 20\%\text{RH}$	
6.3	High Temperature	Test specimens shall be kept standing at $45\pm 2^{\circ}\text{C}$ and below 70% RH or less for 30days	
6.4	Over-discharge	620Ohm continuously discharge down to 0.6V at $20\pm 2^{\circ}\text{C}$, $65\pm 20\%\text{RH}$	

GP Batteries

Product Specifications

Model No.:GPZA675

Document Number: ZA0004

Revision:03

Page 3 of 5

7. QUALITY ASSURANCE

DESCRIPTION	SAMPLING PLAN
Battery dimensions	0.65% (Note 5)
Appearance	1.0% (Note 5)
Off load voltage	0.65% (Note 5)
On load voltage	1.0% (Note 5)
Service output	Note 1 (Note 5)
Leakage 6.1	0.65% (Note 2 & 5)
6.2	Note 3
6.3	Note 4
6.4	Note 4

Note 1 : Acceptance / rejection in accordance with IEC publication 60086-1 (2011), Sub-clause 5.3.

- 1) Test nine batteries.
- 2) Calculate the average without the exclusion of any result.
- 3) If this average is equal to or greater than the specified figure and no more than one battery has a service output of less than 80% of the specified figure, the batteries are considered to conform for service output.
- 4) If this average is less than the specified figure and/or more than one battery has a service output of less than 80% of the specified figure, repeat the test on another sample of nine batteries and calculate the average as previously.
- 5) If the average of this second test is equal to or greater than the specified figure and no more than one battery has a service output of less than 80% of the specified figure, the batteries are considered to conform for service output.
- 6) If the average of second test is less than the specified figure and/or more than one battery has a service output of less than 80% of the specified figure, the batteries are considered not to conform and no further testing is permitted.

Note 2: Leakage on arrival at warehouse is within two months after shipping.

Note 3: Sample size : n=20
Judgement : Ac=1 Re=2

Note 4: Sample size :n=20
Judgement :Ac=0, Re=1

Note 5: AQL General Inspection level II, single sampling plan..

8. PACKAGING

Packaging shall be a form agreed by both parties.

GP Batteries

Product Specifications

Model No.:GPZA675

Document Number: ZA0004

Revision:03

Page 4 of 5

Precaution & Handling

- 1) Do not disassemble or short-circuit batteries.
- 2) Do not recharge batteries.
- 3) Do not dispose of batteries in fire.
- 4) Do not allow metal objects to contact the battery terminals.
- 5) Do not mix with used or other battery type (such as alkaline with carbon zinc).
- 6) Do not solder the batteries directly. If soldering or welding connection to the battery is required, consult our engineer for proper methods.
- 7) Do not over-discharge batteries. Force discharging batteries by external power source in a series may cause explosion.
- 8) To install or remove batteries, follow the equipment manufacturer's instructions.
- 9) Keep battery away from small children. If swallowed, consult a physician at once.
- 10) Remove batteries from device when it is not in use.

Storage

- 1) Store in a cool, dry place before use.
- 2) Do not keep batteries at temperature of 30°C or above.
- 3) Do not keep batteries at relative humidity of 75% or above.

GP Batteries

Product Specifications

Model No.: GPZA675

Document Number: ZA0004

Revision: 03

Page 5 of 5

Drawing 1

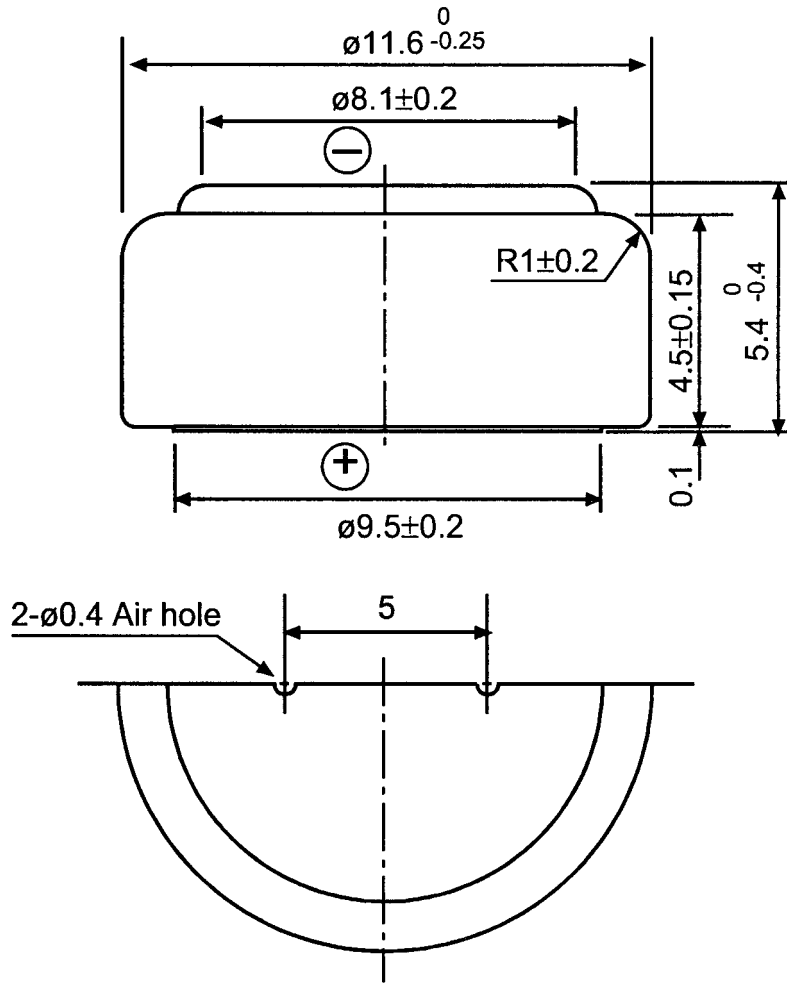

Unit : mm