

P 600 A...P 600 S

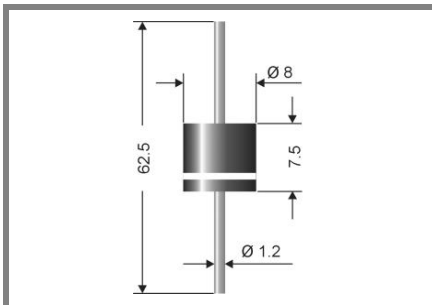

Axial lead diode

Standard silicon rectifier diodes

P 600 A...P 600 S

Forward Current: 6 A

Reverse Voltage: 50 to 1200 V

Features

- Max. solder temperature : 260°C
- Plastic material has UL classification 94V-0

Mechanical Data

- Plastic case 8 x 7.5 [mm] / P-600 Style
- Weight approx.: 1.5 g
- Terminals: plated terminals solderable per MIL-STD-750
- Mounting position: any
- Standard packaging: 500 pieces per ammo

1) Valid, if leads are kept at ambient temperature at a distance of 10 mm from case

2) $I_F = 5A$, $T_j = 25^\circ C$

3) $T_A = 25^\circ C$

Type	Repetitive peak reverse voltage V_{RRM} V	Surge peak reverse voltage V_{RSM} V	Max. reverse recovery time $I_F = -A$ $I_R = -A$ $I_{RR} = -A$ t_{rr} ns	Max. forward voltage $V_F^{(2)}$
P 600 A	50	50	-	1,0
P 600 B	100	100	-	1,0
P 600 D	200	200	-	1,0
P 600 G	400	400	-	1,0
P 600 J	600	600	-	1,0
P 600 K	800	800	-	1,0
P 600 M	1000	1000	-	1,0
P 600 S	1200	1200	-	1,0

Absolute Maximum Ratings

$T_c = 25^\circ C$, unless otherwise specified

Symbol	Conditions	Values	Units
I_{FAV}	Max. averaged fwd. current, R-load, $T_A = 50^\circ C$ 1)	6	A
I_{FRM}	Repetitive peak forward current $f > 15 Hz$ 1)	60	A
I_{FSM}	Peak forward surge current 50 Hz half sinus-wave 3)	400	A
i^2t	Rating for fusing, $t < 10 ms$ 3)	800	A ² s
R_{thA}	Max. thermal resistance junction to ambient 1)	20	K/W
R_{thT}	Max. thermal resistance junction to terminals 1)	-	K/W
T_j	Operating junction temperature	-50...+175	°C
T_s	Storage temperature	-50...+175	°C

Characteristics

$T_c = 25^\circ C$, unless otherwise specified

Symbol	Conditions	Values	Units
I_R	Maximum leakage current, $T_j = 25^\circ C$; $V_R = V_{RRM}$	<25	µA
	$T_j = ^\circ C$; $V_R = V_{RRM}$		
C_j	Typical junction capacitance (at MHz and applied reverse voltage of V)	-	pF
Q_{rr}	Reverse recovery charge ($U_R = V$; $I_F = A$; $dI_F/dt = A/ms$)	-	µC
E_{RSM}	Non repetitive peak reverse avalanche energy ($I_R = mA$; $T_j = ^\circ C$; inductive load switched off)	-	mJ

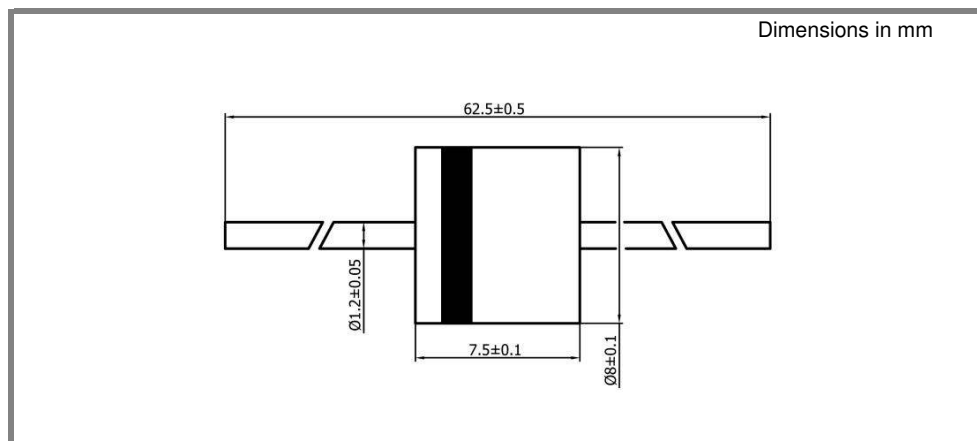

case: 8 x 7,5 [mm]

