



■ Features

- Constant voltage design
- Universal AC input / Full range
- Class II power unit, no FG
- Fully isolated plastic case
- IP42 design
- Small and compact size
- Cooling by free air convection
- Protections: Short circuit / Overload / Over voltage
- No load power consumption <0.5W
- 100% full load burn-in test
- Low cost, high reliability
- 2 years warranty

■ Applications

- Indoor LED lighting
- LED decorative lighting
- LED office lighting
- LED signage

■ Description

APV-8 series is one 8W AC/DC constant voltage mode single output LED power supply. It accepts the full range input 90~264VAC and provides three models with different output voltage, 5V, 12V, 24V, respectively, that the small wattage LED applications employ the most frequently. Exploiting Class II design (without FG pin) and adopting the 94V-0 flame retardant plastic enclosure, APV-8 ideally fits the entry-level LED applications.

■ Model Encoding

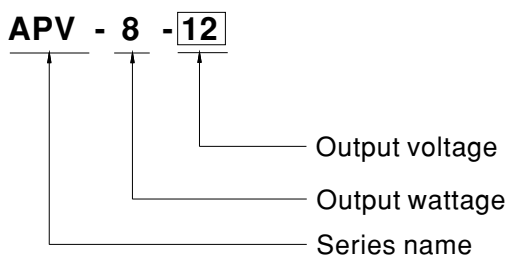



SPECIFICATION

MODEL		APV-8-5	APV-8-12	APV-8-24
OUTPUT	DC VOLTAGE	5V	12V	24V
	RATED CURRENT	1.4A	0.67A	0.34A
	CURRENT RANGE	0 ~ 1.4A	0 ~ 0.67A	0 ~ 0.34A
	RATED POWER	7W	8.04W	8.16W
	RIPPLE & NOISE (max.) Note.2	250mVp-p	250mVp-p	300mVp-p
	VOLTAGE TOLERANCE Note.3	±5.0%		
	LINE REGULATION	±1.0%		
	LOAD REGULATION	±2.0%		
	SETUP, RISE TIME	500ms, 30ms / 230VAC 1500ms,30ms / 115VAC at full load		
	HOLD UP TIME (Typ.)	20ms/230VAC at full load		
INPUT	VOLTAGE RANGE Note.4	90 ~ 264VAC 127 ~ 370VDC (Note.6)		
	FREQUENCY RANGE	47 ~ 63Hz		
	EFFICIENCY (Typ.)	74%	80%	81%
	AC CURRENT	0.15A/230VAC 0.3A/115VAC		
	INRUSH CURRENT(Typ.)	COLD START 70A(twidth=120µs measured at 50% Ipeak) at 230VAC		
	LEAKAGE CURRENT	0.25mA / 240VAC		
PROTECTION	SHORT CIRCUIT	Hiccup mode, recovers automatically after fault condition is removed		
	OVER LOAD	Above 105% rated output power Protection type : Hiccup mode, recovers automatically after fault condition is removed		
	OVER VOLTAGE	5.75 ~ 6.75V	13.8 ~ 16V	27.6 ~ 32.4V
ENVIRONMENT	WORKING TEMP.	-30 ~ +70°C (Refer to "Derating Curve")		
	WORKING HUMIDITY	20 ~ 90% RH non-condensing		
	STORAGE TEMP., HUMIDITY	-40 ~ +80°C, 10 ~ 95% RH		
	TEMP. COEFFICIENT	±0.03%/°C (0 ~ 45°C)		
	VIBRATION	10 ~ 500Hz, 2G 10min./1cycle, period for 60min. each along X, Y, Z axes		
SAFETY & EMC	SAFETY STANDARDS Note.8	UL8750, CSA C22.2 No.250.0-08 approved; design refer to EN60950-1, EN61347-1, EN61347-2-13		
	WITHSTAND VOLTAGE	I/P-O/P:3.75KVAC		
	ISOLATION RESISTANCE	I/P-O/P:>100M Ohms / 500VDC / 25°C / 70% RH		
	EMC EMISSION	Compliance to EN55022, EN61000-3-2 Class A, EN61000-3-3		
	EMC IMMUNITY	Compliance to EN55024, EN61000-4-2, 3, 4, 5, 6, 8, 11; light industry level (surge 2KV), criteria A		
OTHERS	MTBF	1631.5K hrs min. MIL-HDBK-217F (25°C)		
	DIMENSION	60*30*23.5mm(L*W*H)		
	PACKING	0.09Kg; 144pcs/14Kg/0.75CUFT		
NOTE	<p>1. All parameters NOT specially mentioned are measured at 230VAC input, rated load and 25°C of ambient temperature.</p> <p>2. Ripple & noise are measured at 20MHz of bandwidth by using a 12" twisted pair-wire terminated with a 0.1µf & 47µf parallel capacitor.</p> <p>3. Tolerance : includes set up tolerance, line regulation and load regulation.</p> <p>4. Derating may be needed under low input voltage. Please check the static characteristics for more details.</p> <p>5. The power supply is considered as a component that will be operated in combination with final equipment. Since EMC performance will be affected by the complete installation, the final equipment manufacturers must re-qualify EMC Directive on the complete installation again.</p> <p>6. When applying DC voltage for input, please connect the brown input wire to the positive side whereas blue input wire to the negative side.</p> <p>7. The unit might not be suitable for lighting applications in EU countries. Please check with your local authorities for the possible use of the unit.</p> <p>8. The model certified for CCC(GB19510.14, GB19510.1, GB17743 and GB17625.1) is an optional model . Please contact MEAN WELL for details.</p>			

■ Mechanical Specification

Unit:mm

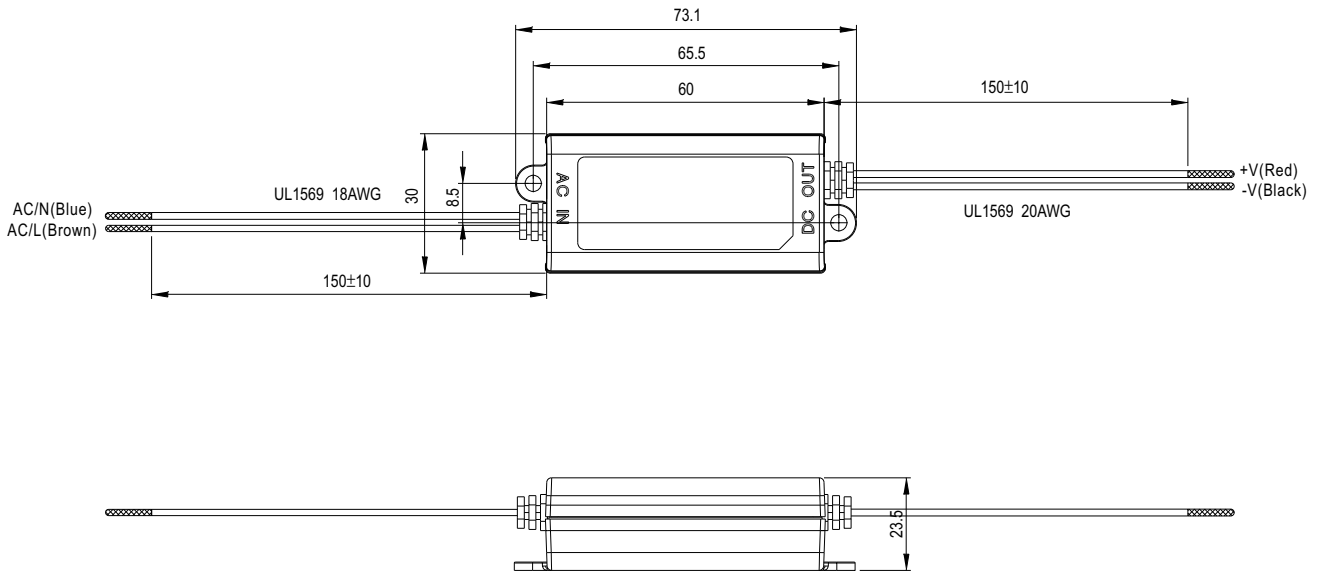

■ Block Diagram

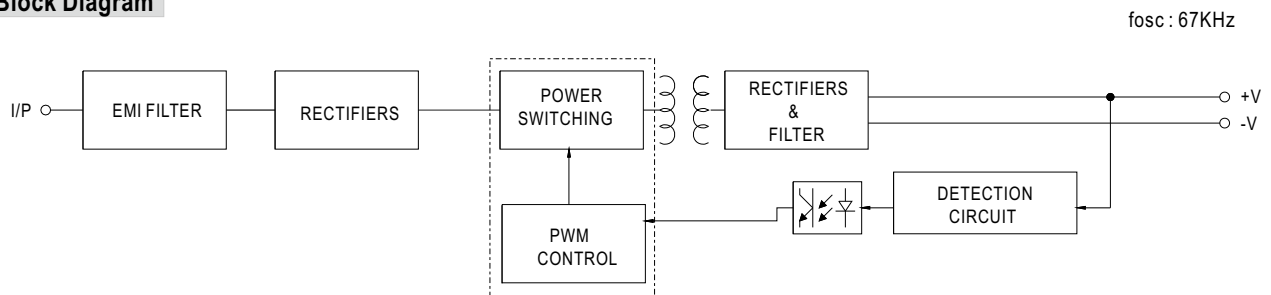

■ Derating Curve

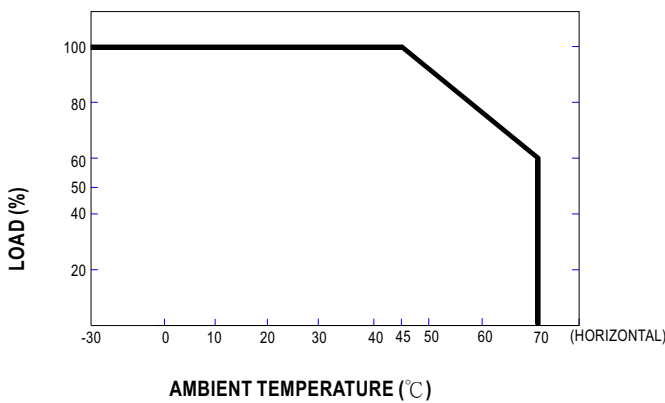

■ Static Characteristics

