



## About keyestudio

Keyestudio is a best-selling brand owned by KEYES Corporation. Our product lines range from controller boards, shields and sensor modules to smart car and complete starter kits for Arduino, Raspberry Pi and BBC micro:bit, which can help customers at any level learn electronics and programming knowledge. Likewise, all of our products comply with international quality standards and are greatly appreciated in a variety of different markets throughout the world.

You can obtain the details and the latest information through visiting the following web sites: <http://www.keyestudio.com>

## \*References and After-sales Service

1. Download Profile : <https://fs.keyestudio.com/KS0345>
2. Feel free to contact us please, if there is missing part or you encounter some troubles. Welcome to send email to us : [service@keyestudio.com](mailto:service@keyestudio.com). We will update projects and products continuously from your sincere advice.

## \*Warning

1. This product contains tiny parts(screws, copper pillars), keep it out of reach of children under 7 years old please.
2. This product contains conductive parts (control board and electronic module). Please operate according to the requirements of tutorial.



Improper operation may cause parts to overheat damage. Do not touch and immediately disconnect the circuit power.

### \*Copyright

The keyestudio trademark and logo are the copyright of KEYES DIY ROBOT co.,LTD. All products under Keyestudio brand can't be copied, sold and resold without authorization by anyone or company. If you're interested in our items, please contact to our sales representatives:

**[fennie@keyestudio.com](mailto:fennie@keyestudio.com)**

## Electronic Scale Kit

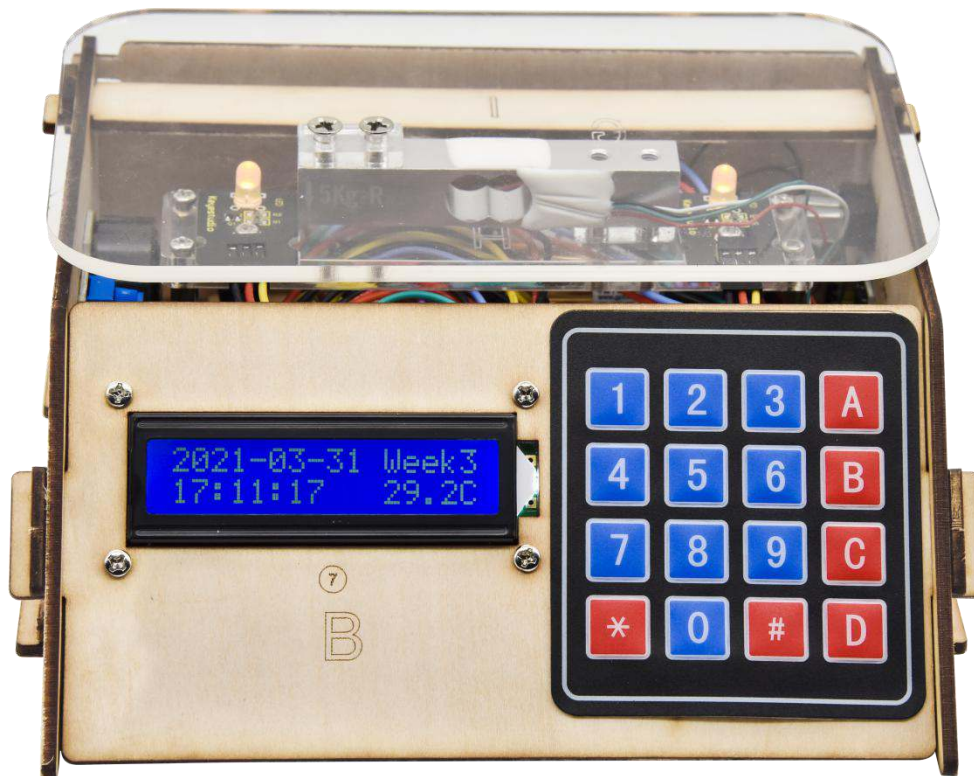

## 1. Description :

When it comes to programming, many think it difficult. However, KEYES group rolls out an electronic scale kit to cope with this problem.

This is a low-cost, easy-to-build and open source programming kit.

In fact, it integrates a large number sensors and modules. You can absorb the basic knowledge of programming like electronics, control logic, computer and science from practical installation.

In compliance with the tutorial, an electronic scale can



be produced by boards, slot connection and wiring.

It also has a membrane keypad, a weighing sensor, a DS3231 module and an LCD 1602 display module

Furthermore, the detailed projects will guide you to learn the working principle of sensors and modules.

If interested in STEM and code programming, you can customize your own scale by altering code and adding extra modules.

That sounds entertaining, right? Let' s get started!

## 2. Features :

1. Multi-purpose function :key input and control , 1602 display , weighing , counting , calculating price , alarm clock , temperature and time display
2. Easy to build : Slot connection and without soldering circuit
3. Novel style : Adopt strong wood board, acrylic board, RGB and LCD 1602 modules.
4. High extension : preserve IIC, UART, SPI ports , and extend other sensors and modules.



5. Basic programming learning : use C language and code.

### 3. Parameters :



Input Voltage : 7-12V

Working Voltage : 5V

Working Current : 100mA

Maximum consumption power : 1.5W

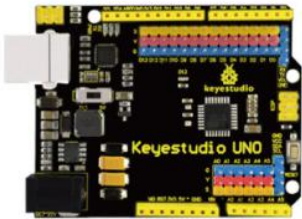
### 3. Kit :

#	Picture	Model	QTY
1		Keyestudio UNO Board	1
2		4pcs Wooden Boards	1













3		2pcs Acrylic Boards	1
4		Keyestudio HX711 Weighing Module	1
5		Micro Weighing Sensor	1
6		4*4 Membrane Keypad	1
7		Keyestudio I2C1602 LCD Module	1
8		Keyestudio DS3231 Clock Module	1
9		Keyestudio Power Amplifier Module	1









10		Keystudio Yellow LED Module	2
11		6-slot AA Battery Holder	1
12		3-pin Rocket Switch	1
13		50g Balance Wight	1
14		100g Balance Wight	1
15		Dual-pass M3*8MM Copper Pillar	8
16		Dual-pass M3*40MM Copper Pillar	4



17		M3*6MM Round Head Screws	8
18		M3*8MM Round Head Screws	13
19		M3*10MM Round Head Screws	3
20		M3*6MM Flat Head Screws	11
21		M4*12MM Flat Head Screws	5
22		M3 Nickel Plated Nuts	11
23		3.0*40MM Screwdriver	1
24		AM/BM OD:5.0 L=50cm USB Cable	1
25		8MM Winding Pipe	1
26		3P F-F Dupont Line	3
27		4P-1P F-F Black/Red/Blue/Gre	1



		en Dupont Line	
28		4P-1P F-F Black/Green/Blue /Red Dupont Line	1
29		4P Dupont Line	1
30		8P M-F Dupont Line	1
31		50*82*0.2MM Plastic Bag	6
32		63*106*0.2MM Plastic Bag	1
33		4CC 4*6CM Plastic Bag	8
34		4CC 10*15CM Plastic Bag	1



## 4. Getting Started with Arduino

### (1) Keyestudio UNO Development Board

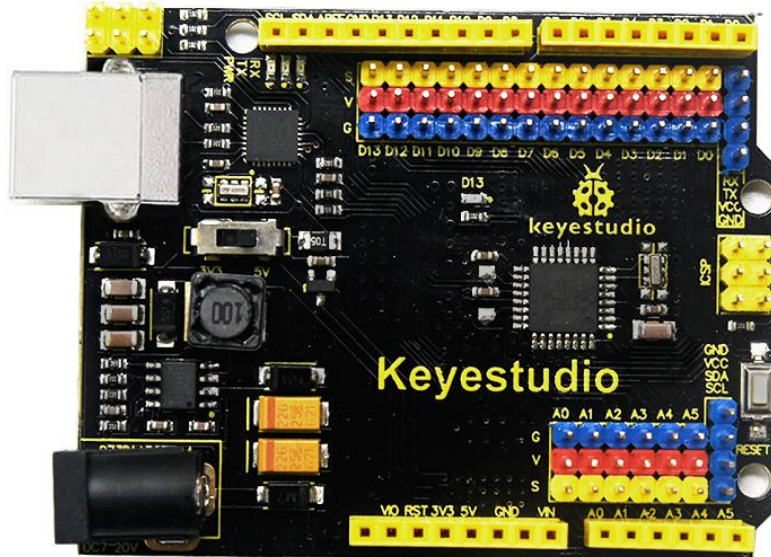

This board has an ATMEGA16U2 chip which can be UART-to-USB conversion plug.

It has 14 digital input/output pins (of which 6 can be used as PWM outputs), 6 analog inputs, a 16 MHz crystal oscillator, a USB connection, a power jack, 1 ICSP headers, and a reset button.

It controls the microcontroller. You can use it by connecting it to computer.



<b>Microcontroller</b>	ATMEGA328P-AU
<b>Operating Voltage</b>	5V
<b>Input Voltage (recommended)</b>	DC7-12V
<b>Digital I/O Pins</b>	14 ↑ (D0-D13)
<b>PWM Digital I/O Pins</b>	6 ↑ (D3 , D5 , D6 , D9 , D10 , D11)
<b>Analog Input Pins</b>	6 (A0-A5)
Flash Memory	32 KB (ATMEGA328P-PU) of which 0.5 KB used by bootloader
SRAM	2 KB (ATMEGA328P-PU)
EEPROM	1 KB (ATMEGA328P-PU)
Clock Speed	16 MHz

Element and Interfaces:

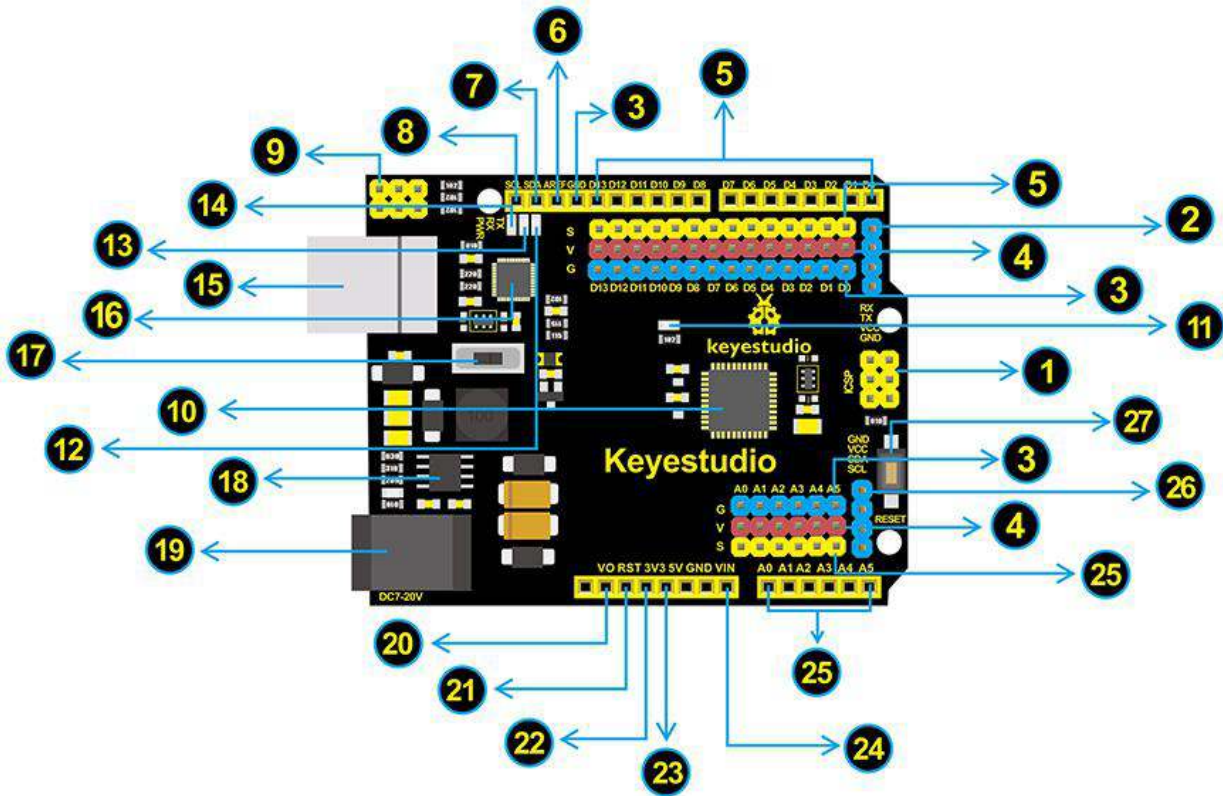

<p><b>1</b></p>	<p><b>ICSP (In-Circuit Serial Programming) Header</b>          ICSP is the AVR, an Arduino micro-program header consisting of MOSI, MISO, SCK, RESET, VCC, and GND. It is often called the SPI (serial peripheral interface) and can be considered an "extension" of the output. In fact, slave the output devices under the SPI bus host. When connecting to PC, program the firmware to ATMEGA328P-AU.</p>
<p><b>2</b></p>	<p><b>Serial Communication Pin</b>          Connect to serial communication.          4Pins (GND, VCC (3.3V or 5V controlled by slide switch), RX, TX)</p>
<p><b>3</b></p>	<p><b>GND</b>          Ground pins</p>



<b>4</b>	<b>V Pins (VCC)</b> Power the external sensors and modules. Select the voltage of 3.3V or 5V via a slide switch.
<b>5</b>	<b>Digital I/O</b> It has 14 digital input/output pins, labeled D0 to D13 (of which 6 can be used as PWM outputs). These pins can be configured as digital input pin to read the logic value (0 or 1). Or used as digital output pin to drive different modules like LED, relay, etc. The pin D3, D5, D6, D9, D10, and D11 can be used to generate PWM. For digital port, you can connect through female headers, or through pin headers (labeled S) of 2.54mm pitch.
<b>6</b>	<b>AREF</b> For Analog reference. Sometimes used to set an external reference voltage (0-5V) as the upper limit of analog input pins.
<b>7</b>	<b>SDA</b> IIC communication pin
<b>8</b>	<b>SCL</b> IIC communication pin
<b>9</b>	<b>ICSP (In-Circuit Serial Programming) Header</b> ICSP is an AVR, an Arduino micro-program header consisting of MOSI, MISO, SCK, RESET, VCC, and GND. Connected to ATMEGA 16U2-MU. When connecting to PC, program the firmware to ATMEGA 16U2-MU.



<b>10</b>	<b>Microcontroller</b> Each control board has its own microcontroller. You can regard it as the brain of your board. Microcontrollers are usually from ATMEL. Before you load a new program on the Arduino IDE, you must know what IC is on your board. This information can be checked at the top of IC. The microcontroller used in this board is <a href="#">ATMEGA328P-AU</a> .
<b>11</b>	<b>D13 LED</b> There is a built-in LED driven by digital pin 13. When the pin is HIGH value, the LED is on, when the pin is LOW, it's off.
<b>12</b>	<b>TX LED</b> Onboard you can find the label: TX (transmit) When UNO board communicates via serial port, send the message, TX led flashes.
<b>13</b>	<b>RX LED</b> Onboard you can find the label: RX(receive ) When UNO board communicates via serial port, receive the message, RX led flashes.
<b>14</b>	<b>Power LED</b> LED on means that your circuit board is correctly powered on. Otherwise LED is off.
<b>15</b>	<b>USB Connection</b> You can power the board via USB connection. Or can upload the program to the board via USB port. Connect the board to PC using a USB cable via USB port.



<b>16</b>	<b>ATMEGA 16U2-MU</b> USB to serial chip, can convert the USB signal into serial port signal.
<b>17</b>	<b>Slide Switch</b> You can slide the switch to control the voltage of pin V (VCC), 3.3V or 5V.
<b>18</b>	<b>Voltage Regulator</b> To control the voltage provided to the UNO board, as well as to stabilize the DC voltage used by the processor and other components. Convert an external input DC7-12V voltage into DC 5V, then switch DC 5V to the processor and other components, output DC 5V, drive current is 2A.
<b>19</b>	<b>DC Power Jack</b> The board can be supplied with an external power DC7-12V from the DC power jack.
<b>20</b>	<b>IOREF</b> Used to configure the operating voltage of microcontrollers. Use it less.
<b>21</b>	<b>RESET Header</b> Connect an external button to reset the board. The function is the same as reset button.
<b>22</b>	<b>Pin 3V3 Output</b> Provides 3.3V voltage output
<b>23</b>	<b>Pin 5V Output</b> Provides 5V voltage output



<b>24</b>	<b>Vin</b> You can supply an external voltage input DC7-12V through this pin to the board.
<b>25</b>	<b>Analog Pins</b> The UNO board has 6 analog inputs, labeled A0 through A5. Can also used as digital pins, A0=D14, A1=D15, A2=D16, A3=D17, A4=D18, A5=D19. For analog port, you can connect through female headers, or through pin headers (labeled S) of 2.54mm pitch.
<b>26</b>	<b>IIC Communication Pin</b> Connect to the IIC communication. 4Pins (GND, VCC (3.3V or 5V controlled by slide switch), SDA, SCL)
<b>27</b>	<b>RESET Button</b> You can reset your board to start the program from the initial status.



## 5. Getting Started with Arduino

### (1) Installing Arduino IDE

When we get control board, we need to download Arduino IDE and driver firstly.

You could download Arduino IDE from the official website:

<https://www.arduino.cc/>, click the **SOFTWARE** on the browse bar, click “**DOWNLOADS**” to enter download page, as shown below:

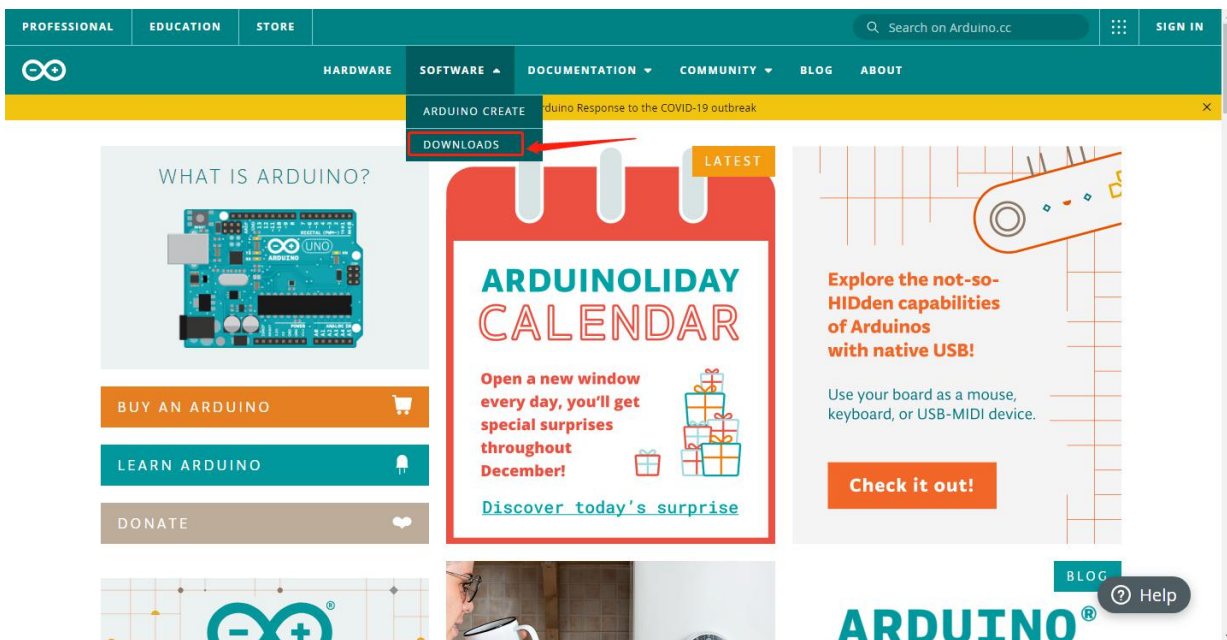

You can download either **Windows win7 and newer** or **Windows ZIP file**.

The first one doesn't require

There are two versions of IDE for WINDOWS system, you can choose from the Installer (.exe) and the Zip packages. We suggest you use the first one that installs directly everything you need to use the Arduino Software (IDE),



including the drivers.

With the Zip package you need to install the drivers manually. The Zip file is also useful if you want to create a portable installation.

## Downloads

 **Arduino IDE 1.8.13**

The open-source Arduino Software (IDE) makes it easy to write code and upload it to the board. This software can be used with any Arduino board.

Refer to the [Getting Started](#) page for Installation instructions.

SOURCE CODE

Active development of the Arduino software is [hosted by GitHub](#). See the instructions for [building the code](#). Latest release source code archives are available [here](#). The archives are PGP-signed so they can be verified using [this](#) gpg key.

**DOWNLOAD OPTIONS**

- Windows** Win 7 and newer
- Windows** ZIP file
- Windows app** Win 8.1 or 10 [Get](#)
- Linux** 32 bits
- Linux** 64 bits
- Linux** ARM 32 bits
- Linux** ARM 64 bits
- Mac OS X** 10.10 or newer

[Release Notes](#)  
[Checksums \(sha512\)](#)