

DATE	DESCRIPTION	REV.
2.9.05	CHANGE AS PER ECN 05-013	H

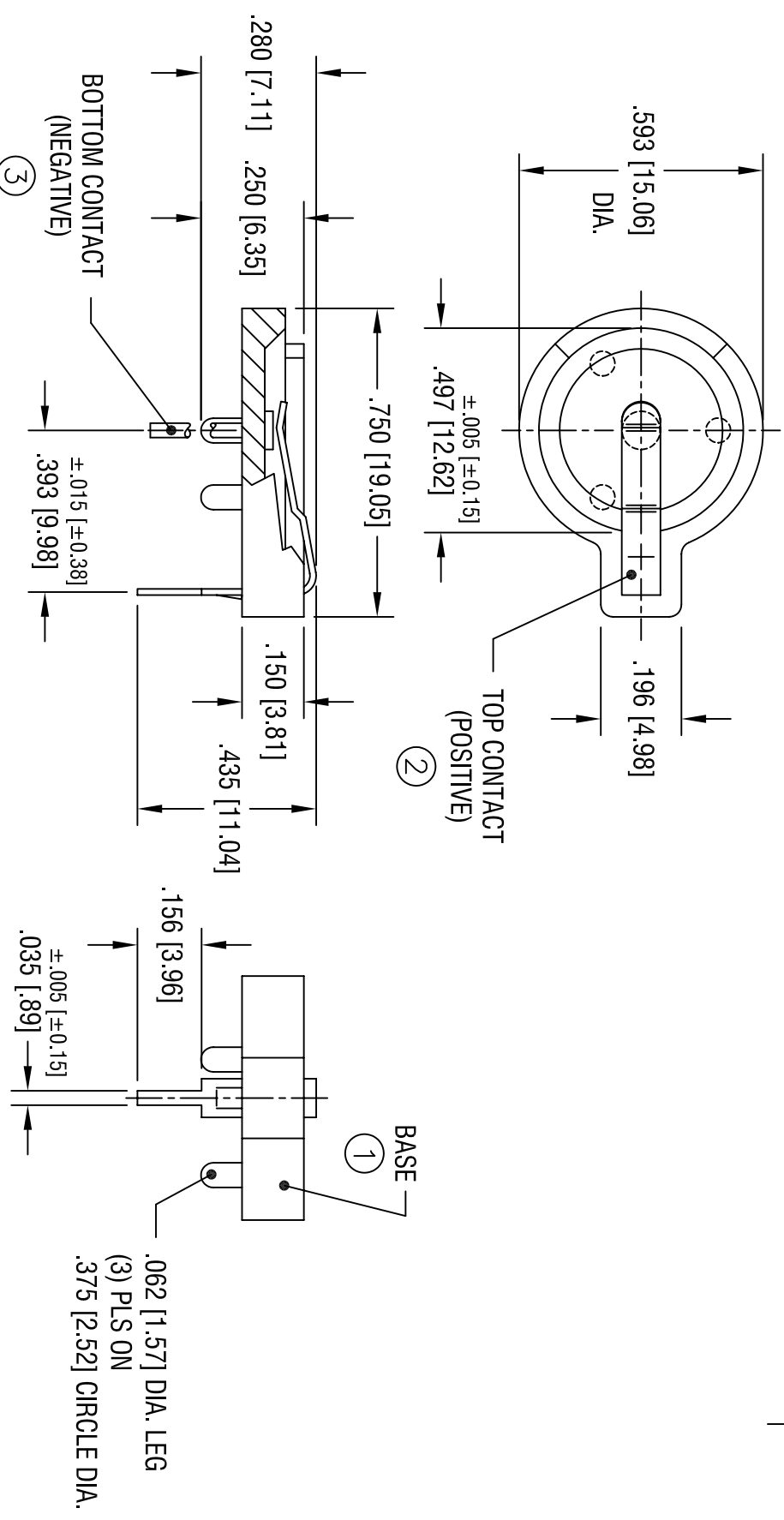

MOUNTING DETAIL

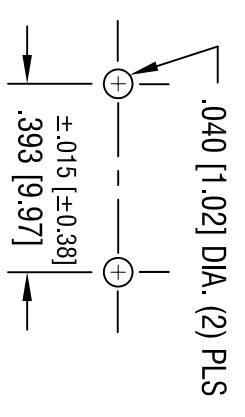

ITEM	DESCRIPTION/MATERIAL
①	BASE, BLACK PBT (UL 94V-0)
②	TOP CONTACT .015 [0.38] TH'K SPRING STEEL
③	BOTTOM CONTACT .035 [0.89] DIA. STEEL

FINISH
TIN NICKEL PLATE

KEYSTONE ELECTRONICS CORP.
ASTORIA, N.Y. 11105-2017

PART NAME
12mm PC BATTERY HOLDER

MATERIAL
AS NOTED

FINISH
AS NOTED

TOLERANCES	INCH	[MM]	CODE	DWG NO.
DECIMAL	± .010	[± 0.25]	C	500
ANGULAR	± 1°			

THIS DOCUMENT IS THE PROPERTY OF
KEYSTONE ELECTRONICS CORP. AND
SHALL NOT BE REPRODUCED, DISTRIBUTED
OR USED AS A BASIS FOR MANUFACTURE
WITHOUT PRIOR WRITTEN PERMISSION
FROM KEYSTONE ELECTRONICS CORP.

DRN BY
BOONE

DATE
1.4.91

App'd
LN

SCALE
2.5X