

**isc Silicon PNP Power Transistor**

**BD908**

**DESCRIPTION**

- DC Current Gain -  
:  $h_{FE} = 40 @ I_C = -0.5A$
- Collector-Emitter Sustaining Voltage-  
:  $V_{CEO(SUS)} = -60V(\text{Min})$
- Complement to Type BD907

**APPLICATIONS**

- Designed for use in general purpose power amplifier and switching applications.

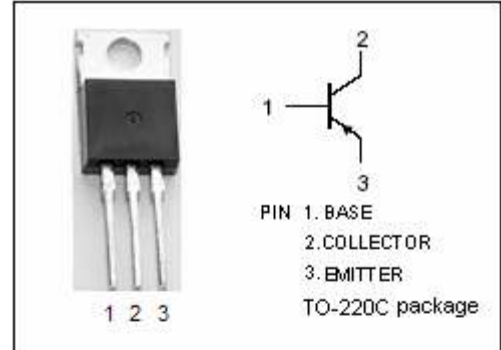

**ABSOLUTE MAXIMUM RATINGS( $T_a=25^\circ\text{C}$ )**

SYMBOL	PARAMETER	VALUE	UNIT
$V_{CBO}$	Collector-Base Voltage	-60	V
$V_{CEO}$	Collector-Emitter Voltage	-60	V
$V_{EBO}$	Emitter-Base Voltage	-5	V
$I_C$	Collector Current-Continuous	-15	A
$I_{CM}$	Collector Current-Peak	-20	A
$I_B$	Base Current	-5	A
$P_C$	Collector Power Dissipation @ $T_C=25^\circ\text{C}$	90	W
$T_J$	Junction Temperature	150	$^\circ\text{C}$
$T_{stg}$	Storage Temperature Range	-65~150	$^\circ\text{C}$

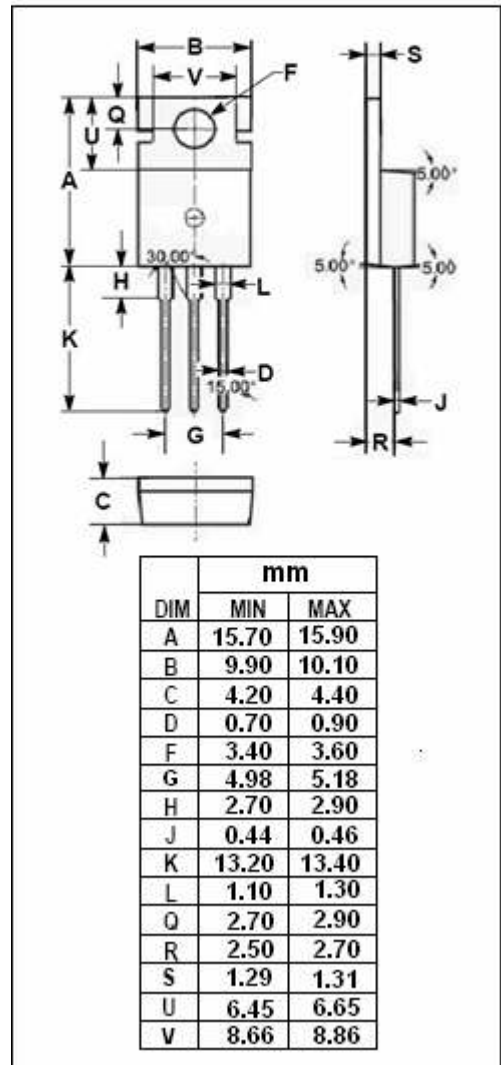

**THERMAL CHARACTERISTICS**

SYMBOL	PARAMETER	MAX	UNIT
$R_{th\ j-c}$	Thermal Resistance, Junction to Case	1.38	$^\circ\text{C}/\text{W}$

## isc Silicon PNP Power Transistor

BD908

## ELECTRICAL CHARACTERISTICS

 $T_C=25^\circ\text{C}$  unless otherwise specified

SYMBOL	PARAMETER	CONDITIONS	MIN	MAX	UNIT
$V_{CEO(SUS)}$	Collector-Emitter Sustaining Voltage	$I_C = -50\text{mA}; I_B = 0$	-60		V
$V_{CE(sat)-1}$	Collector-Emitter Saturation Voltage	$I_C = -5\text{A}; I_B = -0.5\text{A}$		-1.0	V
$V_{CE(sat)-2}$	Collector-Emitter Saturation Voltage	$I_C = -10\text{A}; I_B = -2.5\text{A}$		-3.0	V
$V_{BE(sat)}$	Base-Emitter Saturation Voltage	$I_C = -10\text{A}; I_B = -2.5\text{A}$		-2.5	V
$V_{BE(on)}$	Base-Emitter On Voltage	$I_C = -5\text{A}; V_{CE} = -4\text{V}$		-1.5	V
$I_{CBO}$	Collector Cutoff Current	$V_{CB} = -60\text{V}; I_E = 0$		-0.5	mA
$I_{CEO}$	Collector Cutoff Current	$V_{CE} = -30\text{V}; I_B = 0$		-1.0	mA
$I_{EBO}$	Emitter Cutoff Current	$V_{EB} = -5\text{V}; I_C = 0$		-1.0	mA
$h_{FE-1}$	DC Current Gain	$I_C = -0.5\text{A}; V_{CE} = -4\text{V}$	40	250	
$h_{FE-2}$	DC Current Gain	$I_C = -5\text{A}; V_{CE} = -4\text{V}$	15	150	
$h_{FE-3}$	DC Current Gain	$I_C = -10\text{A}; V_{CE} = -4\text{V}$	5		
$f_T$	Current-Gain—Bandwidth Product	$I_C = -0.5\text{A}; V_{CE} = -4\text{V}; f_{test} = 1.0\text{MHz}$	3.0		MHz