

尺寸标注及检具说明：尺寸标有以下符号的尺寸为重点尺寸！

“C” 卡尺 “P” 塞规 “M” 千分尺 “H” 高度计 “MS” 工显或影像仪 “GE” 齿轮啮合仪 “G” 齿轮检测中心 “TM” 三次元 “Q” 其他重检项目

序号 日期 变更内容 修改者

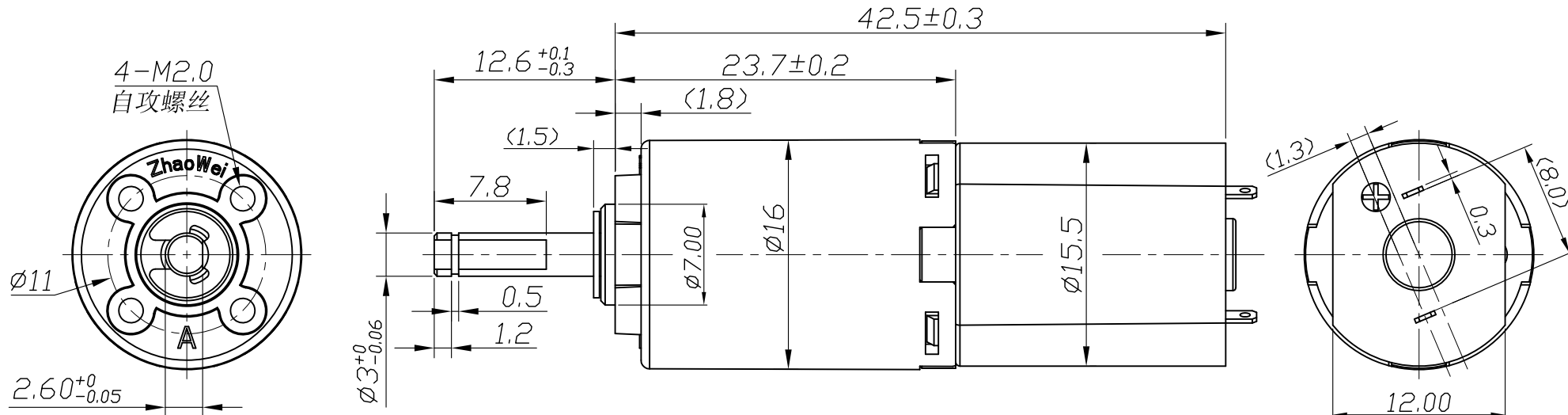

GEAR MOTOR DATA:

1	Rated Voltage	6.0 VDC	2	No Load Current	120mA MAX
3	No Load Speed	24±15% rpm	4	Rated Torque	486gf.cm
5	Rated Current	0.2A MAX	6	Rated Speed	22±15%rpm
7	Stall Torque	2500gf.cm	8	Stall Current	0.6A MAX
9	Gear Ratio	384:1	10	No Load Noise	60 db

Test Method: Detector with sponge to gearbox side at 10cm in ambient noise under 32dB.

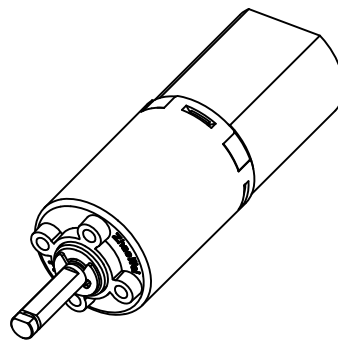

TECHNICAL REQUIREMENTS:

- 1.No defects such as crack, scratch, burr and deformation.
- 2.Dimensions in bracket for reference.
- 3.No abnormal noise in testing.
- 4.RoHS compliant.

产品名称	Ø16行星齿轮箱	未注公差	产品代码	ZWPD016016-384																									
客户名称	陶政邦	<table border="1"> <tr> <th colspan="3">TOLERANCE TABLE (mm)</th> </tr> <tr> <th></th> <th>IT 11</th> <th>IT 12</th> </tr> <tr> <td>0-3</td> <td>0.06</td> <td>0.10</td> </tr> <tr> <td>3-6</td> <td>0.075</td> <td>0.12</td> </tr> <tr> <td>6-10</td> <td>0.09</td> <td>0.15</td> </tr> <tr> <td>10-18</td> <td>0.11</td> <td>0.18</td> </tr> <tr> <td>18-30</td> <td>0.13</td> <td>0.21</td> </tr> <tr> <td>30-50</td> <td>0.16</td> <td>0.25</td> </tr> </table>	TOLERANCE TABLE (mm)				IT 11	IT 12	0-3	0.06	0.10	3-6	0.075	0.12	6-10	0.09	0.15	10-18	0.11	0.18	18-30	0.13	0.21	30-50	0.16	0.25	共 1 张	版本	A
TOLERANCE TABLE (mm)																													
	IT 11	IT 12																											
0-3	0.06	0.10																											
3-6	0.075	0.12																											
6-10	0.09	0.15																											
10-18	0.11	0.18																											
18-30	0.13	0.21																											
30-50	0.16	0.25																											
设计	2015-04-08		第 1 张	比例	1:1																								
审核		符合《ROHS相关禁止物质标准》																											
批准		ZHAOWEI 兆威																											