

Specification

Part No.: HUWH-5101L-Y

► Main descriptions:

- Standard $\Phi 5\text{mm}$ super bright lamp LED
- Single color: Warm White
- Lens Type: Water Clear
- Dice Material: AlGaInP
- High intensity, reliability and long life
- Environmental friendly, RoHs compliant
- Mainly used in lighting area or as signal lamp

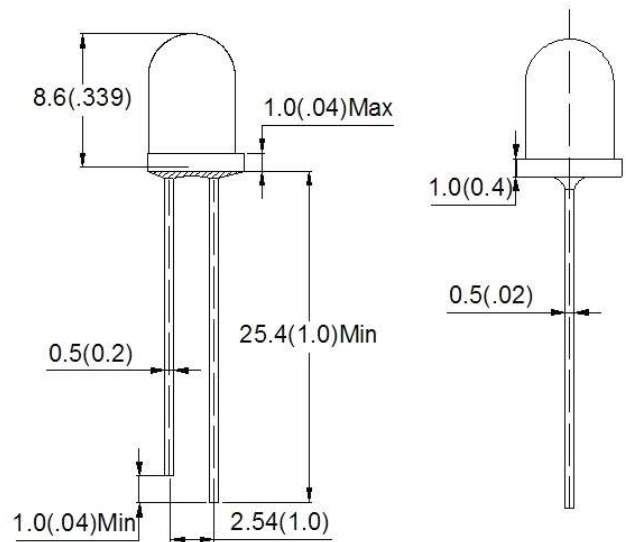
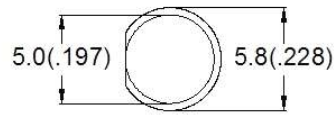

NOTE:

1. All dimensions are in millimeter (Inches).
2. Tolerance is $\pm 0.25\text{ mm}$ (.010") unless otherwise noted.
3. Specifications are subject to change without notice.

DIRECTIVITY

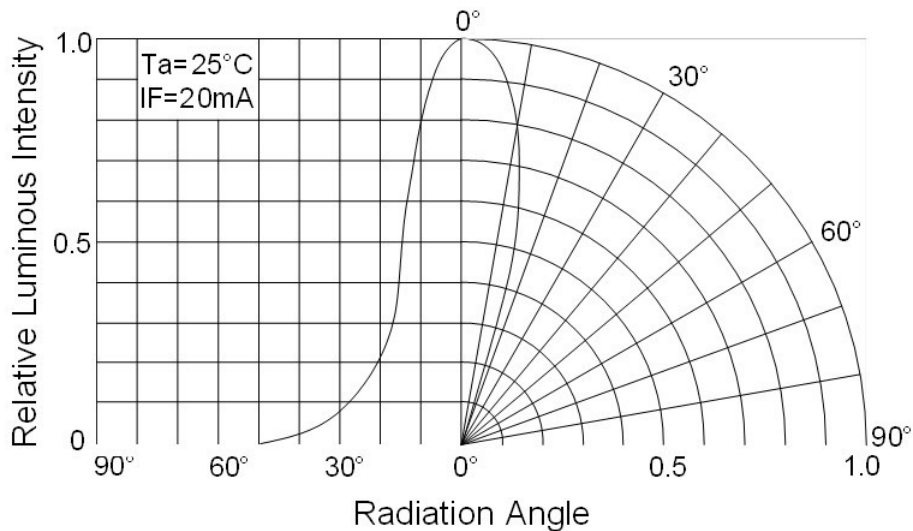

◆ **Absolute Maximum Rating** (Ta=25°C)

Series	Symbol	Testing Condition	Characteristics		Unit
			Min.	Max.	
Power Dissipation	Pd	—	—	120	mW
Reverse Voltage	VR	IR = 50μA	6	—	V
Peak Forward Current	Ipeak	Duty=0.1, 1kHz	—	100	mA
Derating Linear	I/C	—	—	0.4	mA/°C
Operating Temperature Range	Topr	—	-25	+80	°C
Storage Temperature Range	Tstr	—	-40	+100	°C
Lead Soldering Temperature	Tsol	260°C for 5sec. (3.0mm from resin)			
Anti-static Voltage	1000				V

◆ **Electrical and optical characteristics** (Ta = 25°C)

Series	Symbol	Test Condition	Characteristics			Unit
			Min.	Typ.	Max.	
Forward Voltage	VF	IF=20mA	3.0	3.2	3.4	V
Reverse Current	IR	VR=5V	—	—	30	μA
Color Temperature	CT	IF=20mA	2700-3500			K
Luminous Intensity	Iv	IF=20mA	12000	15000	—	mcd
Viewing Angle	2θ1/2	IF=20mA	—	15	—	deg.

◆ Soldering Condition

Careful attention should be paid during soldering. When soldering, leave more than 2mm from solder joint to case, and soldering beyond the base of the tie bar is recommended.

Avoiding applying any stress to the lead frame while the LEDs are at high temperature particularly when soldering.

Recommended soldering conditions

Hand Soldering		DIP Soldering	
Temp.at tip of iron	300°C Max.(30WMax.)	Preheat temp.	100°C Max. (60 sec Max.)
Soldering time	3 sec Max.	Bath temp.	260°C Max
Distance	2mm Min.(From solder joint to case)	Bath time.	3 sec Max.
		Distance	2mm Min

Packing messenger

Packing method: plastic bag	1K / bag	Net weight: 0.3kg/K
size of inner box is 34X21X12cm	8K/box max	Gross weight: 2.6kgs/box
size of outer box is 43X34.5X37c	48K/box max	Gross weigh: 16kgs/box

◆ Notes

This datasheet will be update regularly, if there comes out any changes, pls confirmed by the latest datasheet.