

Features

- Wide-range supply voltage, up to 40 V
- Single or split power supply
- Short-circuit protection to ground
- Thermal shutdown
- $P_O = 25\text{ W}$ @ THD = 0.5%, $V_S = \pm 17\text{ V}$, $R_L = 4\ \Omega$
- $P_O = 30\text{ W}$ @ THD = 10%, $V_S = \pm 17\text{ V}$, $R_L = 4\ \Omega$

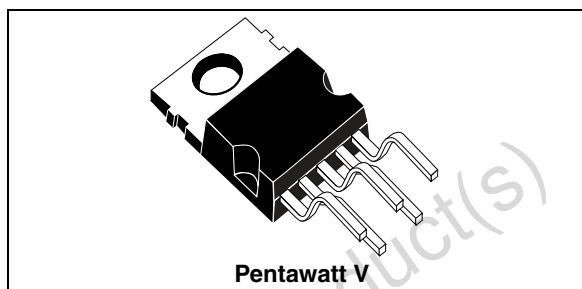

Description

The TDA2040 is a monolithic integrated circuit in the Pentawatt® package, intended for use as an audio class-AB amplifier. Typically, it provides 25 W output power into 4 Ω with THD = 0.5% at $V_S = 34\text{ V}$. The TDA2040 provides high output current and has very low harmonic and crossover distortion. Furthermore, the device incorporates a patented short-circuit protection system

comprising an arrangement for automatically limiting the dissipated power so as to keep the operating point of the output transistors within their safe operating range. A thermal shutdown system is also included.

Table 1. Device summary

Order code	Package
TDA2040V	Pentawatt V (vertical)

Figure 1. TDA2040 test circuit

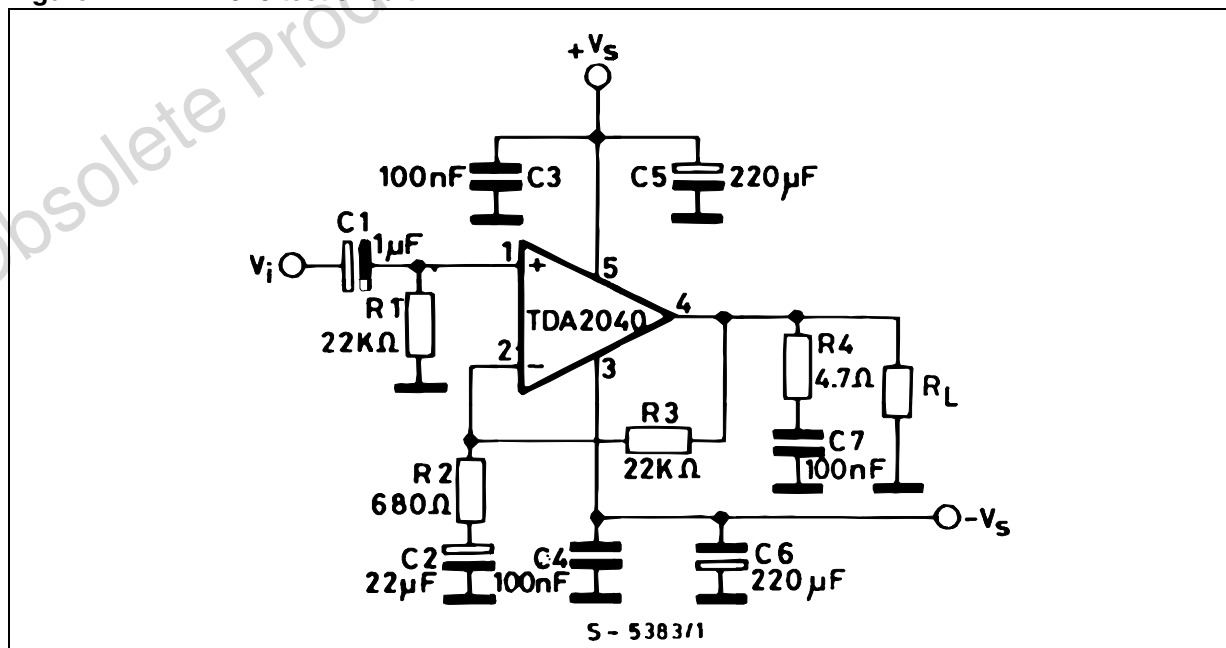

1 Pin connections

Figure 2. Schematic diagram

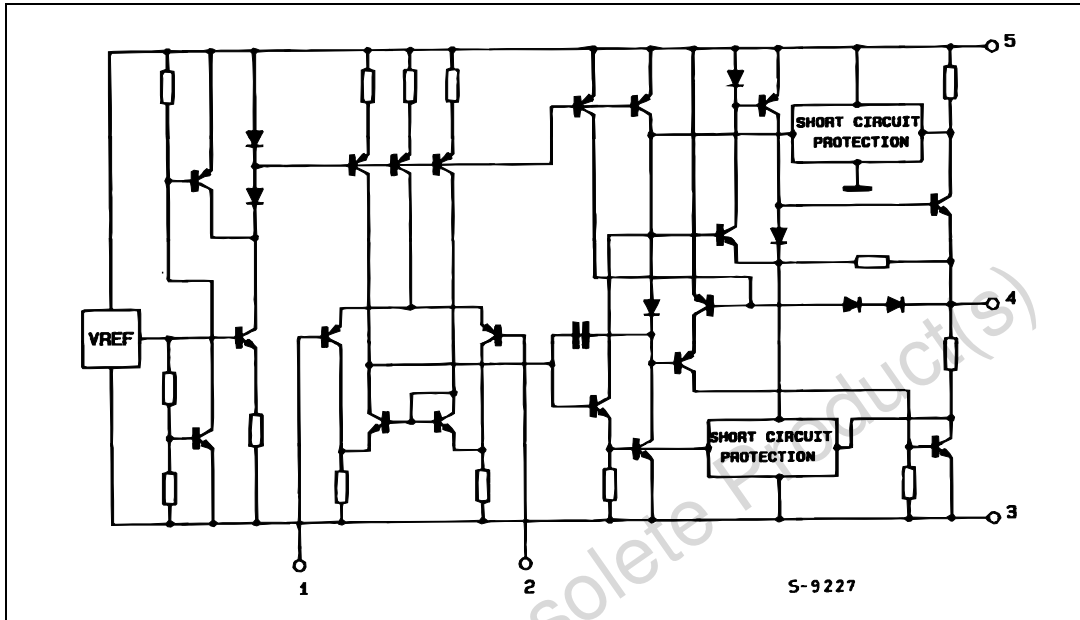
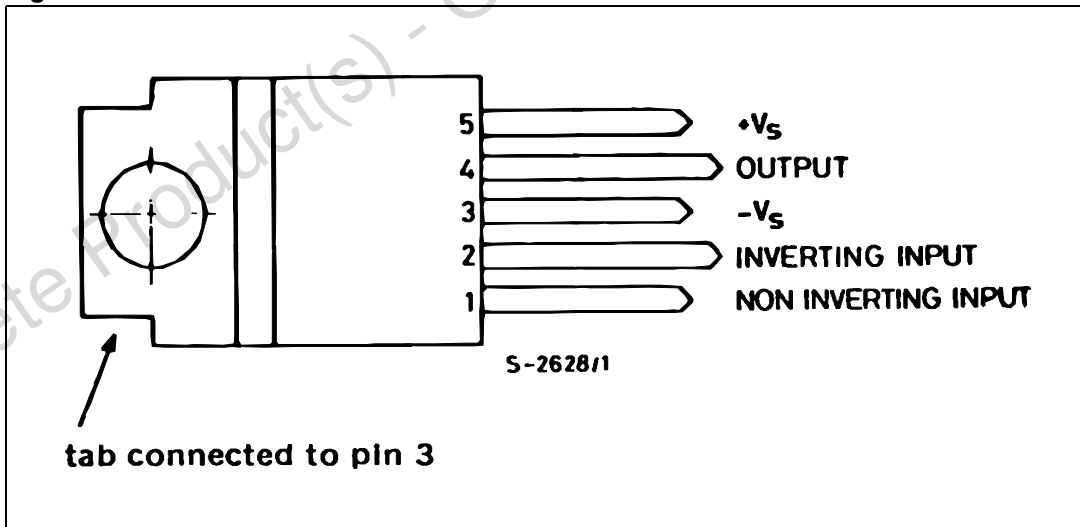

Figure 3. Pin connections



2 Electrical specifications

2.1 Absolute maximum ratings

Table 2. Absolute maximum ratings

Symbol	Parameter	Value	Unit
V _s	Supply voltage	±20	V
V _i	Input voltage	V _s	
V _i	Differential input voltage	±15	V
I _o	Output peak current (internally limited)	4	A
P _{tot}	Power dissipation at T _{case} = 75 °C	25	W
T _{stg} , T _j	Storage and junction temperature	-40 to 150	°C
V _{ESD_HBM}	ESD maximum withstanding voltage range, test condition CDF-AEC-Q100-002- "Human body model"	±1500	V

2.2 Thermal data

Table 3. Thermal data

Symbol	Parameter	Min	Typ	Max	Unit
R _{th_j-case}	Thermal resistance junction to case	-	-	3	°C/W

2.3 Electrical characteristics

The specifications given here were obtained with the conditions $V_S = \pm 16\text{ V}$, $T_{\text{amb}} = 25\text{ }^\circ\text{C}$ unless otherwise specified.

Table 4. Electrical characteristics

Symbol	Parameter	Test conditions	Min	Typ	Max	Unit
V_S	Supply voltage	-	± 4.5	-	± 20	V
I_d	Quiescent drain current	$V_S = \pm 4.5\text{ V}$ $V_S = \pm 20\text{ V}$	-	- 45	30 100	mA mA
I_b	Input bias current	$V_S = \pm 20\text{ V}$	-	0.3	1	μA
V_{OS}	Input offset voltage	$V_S = \pm 20\text{ V}$	-	± 2	± 20	mV
I_{OS}	Input offset current	-	-	-	± 200	nA
P_o	Output power	$d = 0.5\%$, $f = 1\text{ kHz}$, $T_{\text{amb}} = 60\text{ }^\circ\text{C}$ $R_L = 4\ \Omega$ $R_L = 4\ \Omega$, $V_S = \pm 17$ $R_L = 8\ \Omega$	20	22 25 12	-	W
		$d = 0.5\%$, $f = 15\text{ kHz}$; $T_{\text{amb}} = 60\text{ }^\circ\text{C}$ $R_L = 4\ \Omega$ $R_L = 4\ \Omega$, $V_S = \pm 17$	15	18 20	-	
		$d = 10\%$, $f = 1\text{ kHz}$ $R_L = 4\ \Omega$, $V_S = \pm 17$	-	30	-	
BW	Power bandwidth	$P_o = 1\text{ W}$, $R_L = 4\ \Omega$	-	100	-	Hz
G_{VOL}	Voltage gain (open loop)	$f = 1\text{ kHz}$	-	80	-	dB
G_V	Voltage gain (closed loop)	$f = 1\text{ kHz}$	29.5	30	30.5	dB
d	Total harmonic distortion	$P_o = 0.1\text{ to }10\text{ W}$, $R_L = 4\ \Omega$, $f = 40\text{ to }15000\text{ Hz}$	-	0.08	-	%
		$P_o = 0.1\text{ to }10\text{ W}$, $R_L = 4\ \Omega$, $f = 1\text{ kHz}$	-	0.03	-	%
e_N	Input noise voltage	B = Curve A B = 22 Hz to 22 kHz	- -	2 3	- 10	μV
I_N	Input noise current	B = Curve A B = 22 Hz to 22 kHz	- -	50 80	- 200	μA
R_i	Input resistance (pin 1)	-	0.5	5	-	$\text{M}\Omega$
SVRR	Supply voltage rejection ratio	$G_V = 30\text{ dB}$, $R_L = 4\ \Omega$, $R_g = 22\text{ k}\Omega$, $f = 100\text{ Hz}$ $V_{\text{ripple}} = 0.5\text{ V RMS}$	40	50	-	dB
h	Efficiency	$f = 1\text{ kHz}$ $P_o = 12\text{ W}$, $R_L = 8\ \Omega$ $P_o = 22\text{ W}$, $R_L = 4\ \Omega$	- -	66 63	- -	%
			-	-	145	$^\circ\text{C}$

2.4 Characterizations

Figure 4. Output power vs. supply voltage

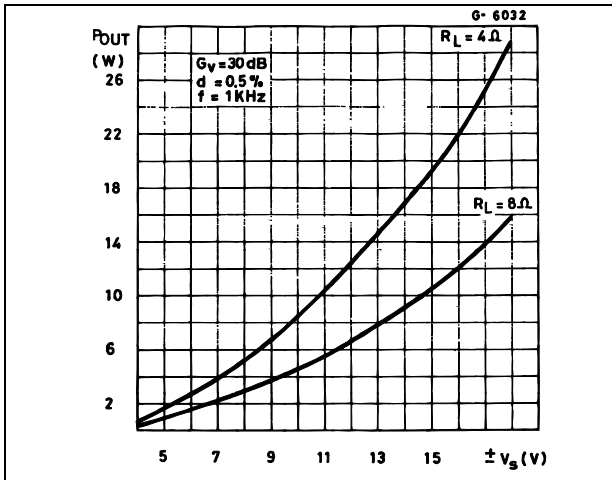

Figure 5. Output power vs. supply voltage

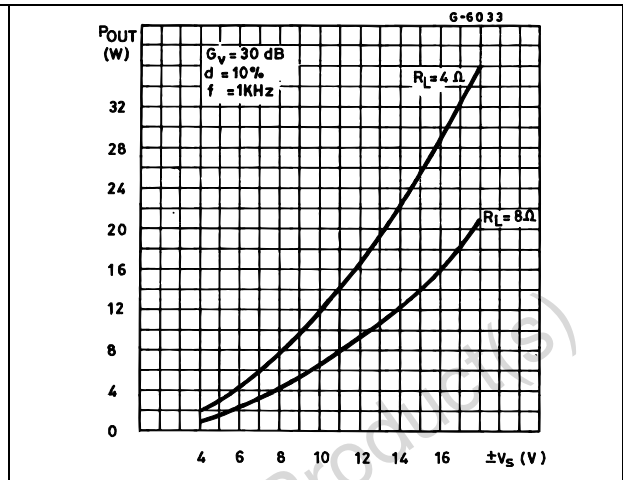

Figure 6. Output power vs. supply voltage

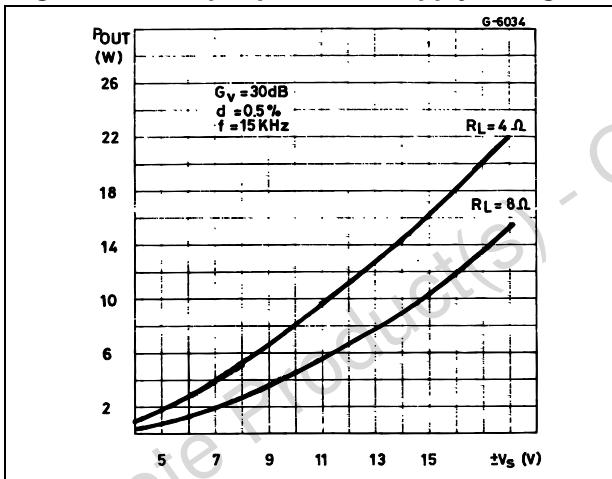

Figure 7. Distortion vs. frequency

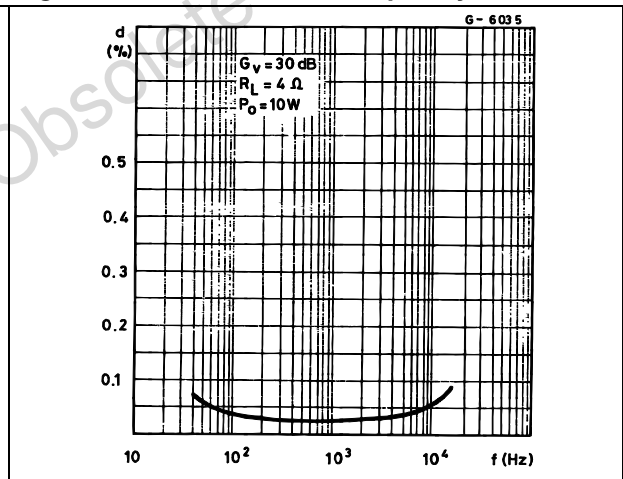

Figure 8. SVRR vs. frequency

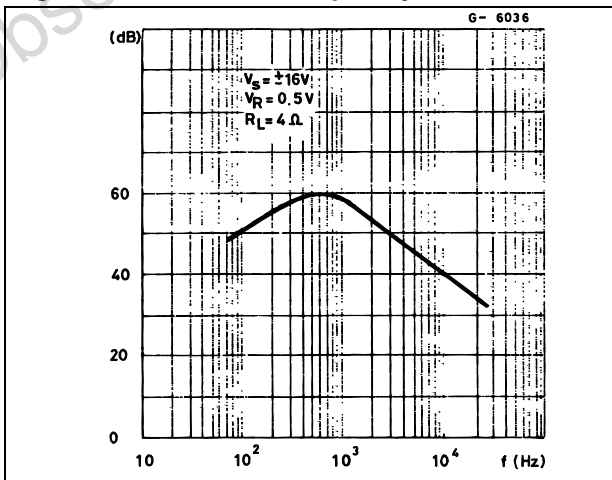

Figure 9. SVRR vs. voltage gain

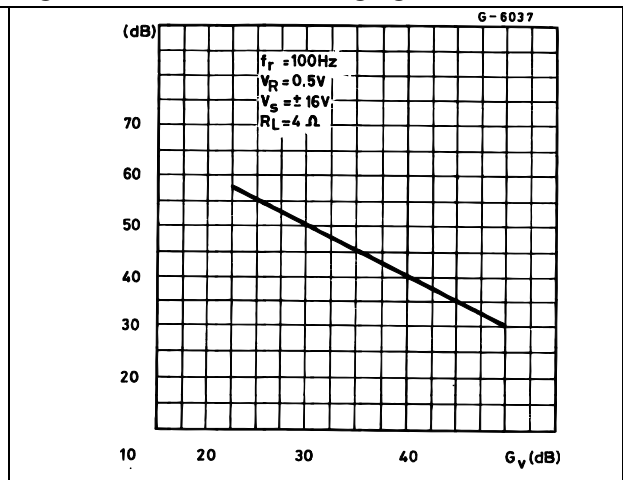

Figure 10. Quiescent drain current vs. supply voltage

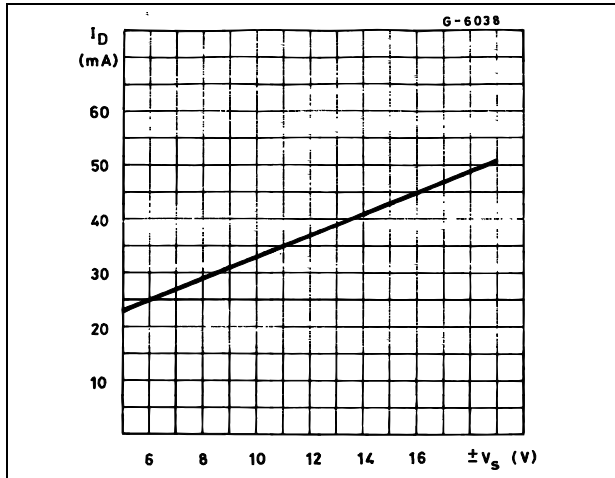

Figure 11. Open loop gain vs. frequency

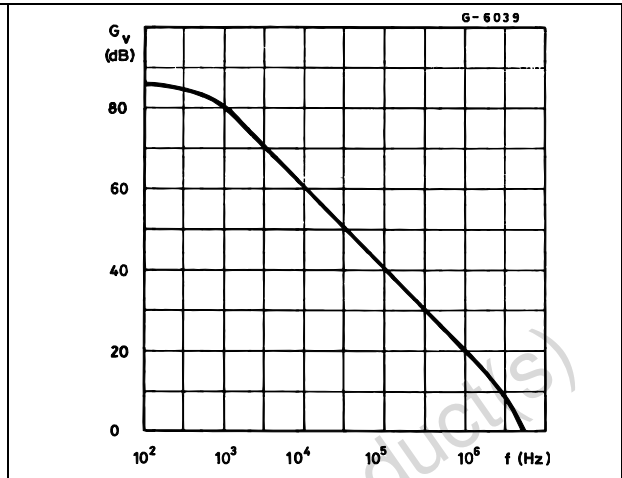
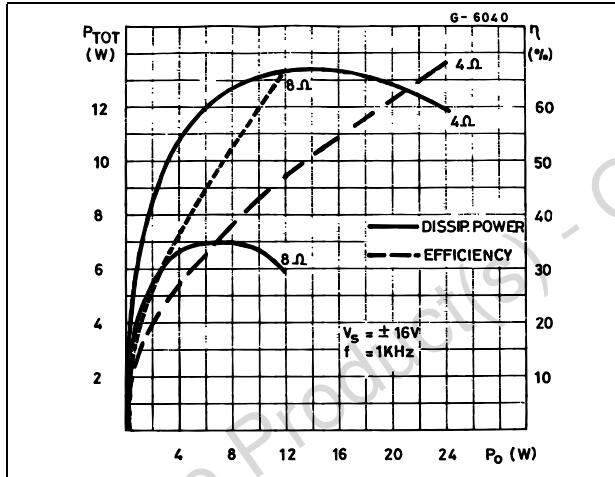

Figure 12. Power dissipation vs. output power



3 Applications

3.1 Circuits and PCB layout

Figure 13. Amplifier with split power supply

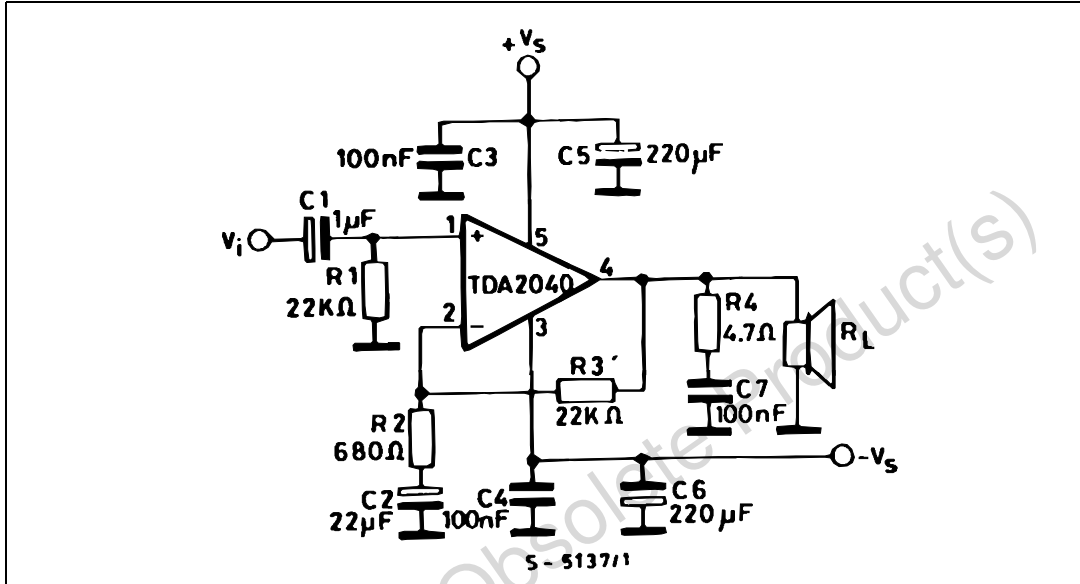

Figure 14. PCB and components layout for the circuit of the amplifier with split power supply

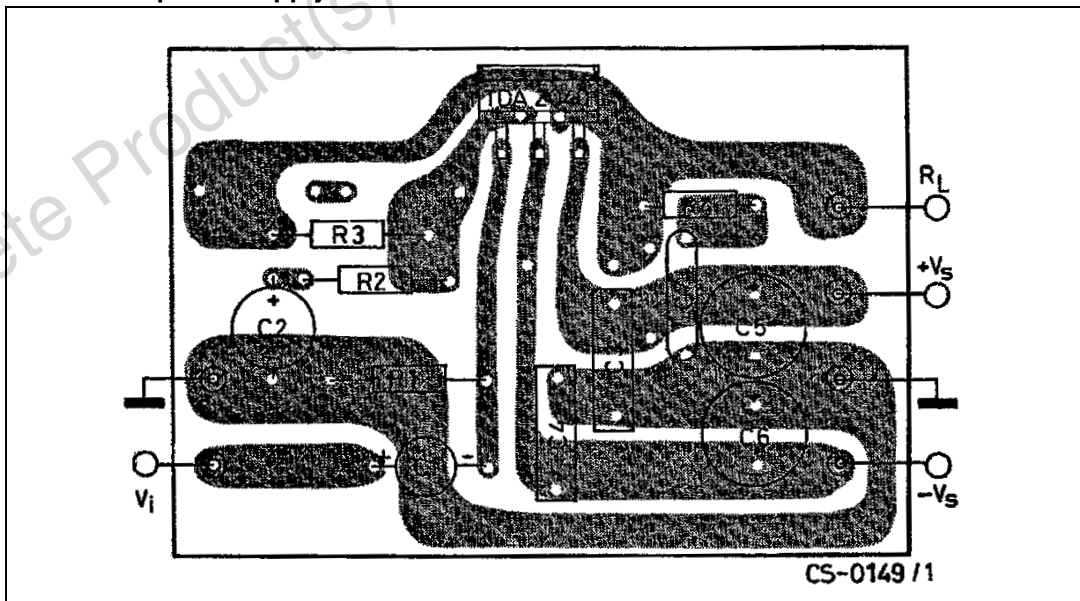

Figure 15. Amplifier with single power supply

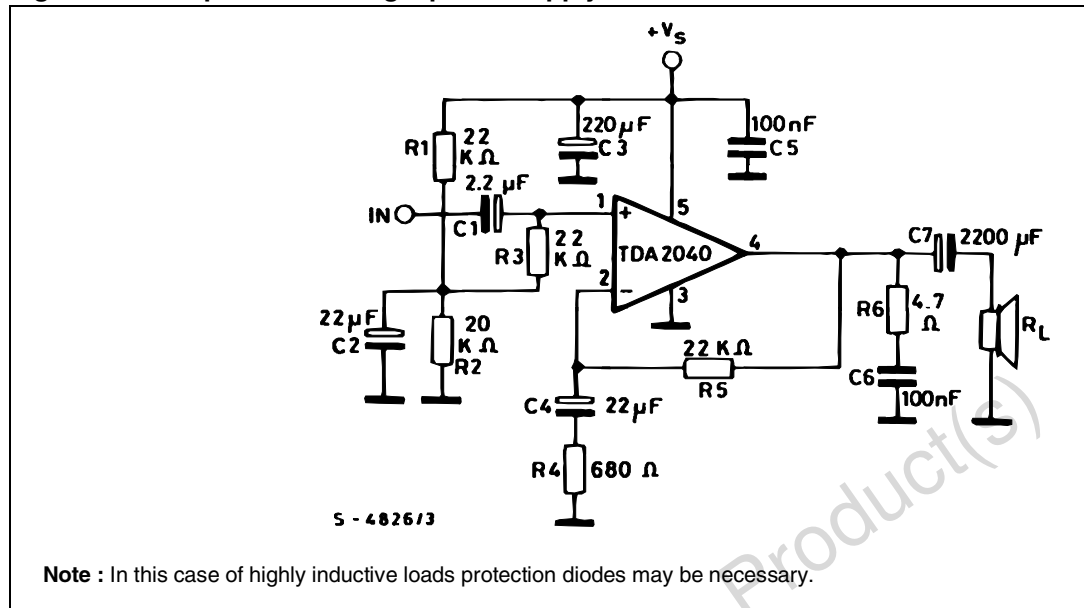

Figure 16. PCB and components layout for the circuit of the amplifier with single power supply

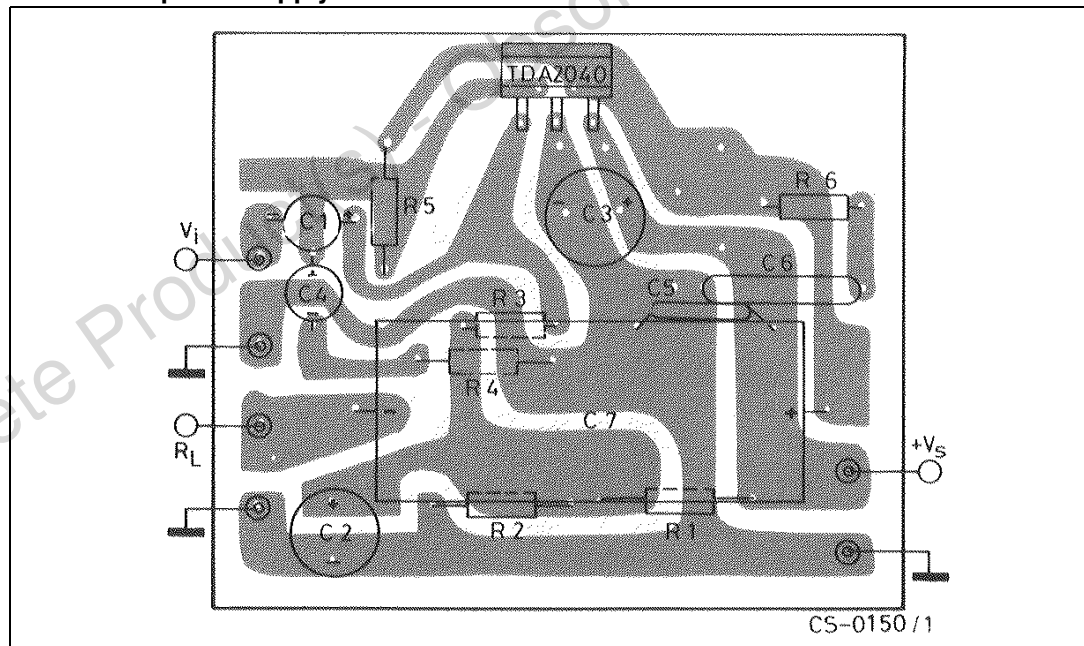

Figure 17. 30-watt bridge amplifier with split power supply

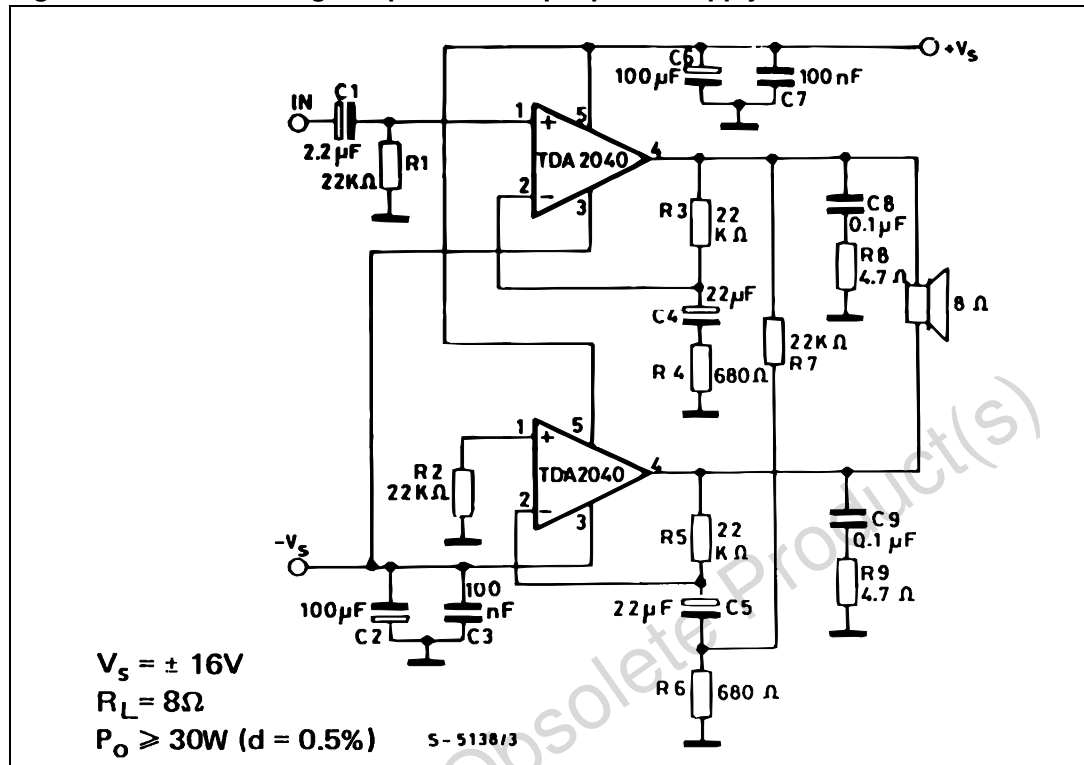

Figure 18. PCB and components layout for the circuit of the 30-watt bridge amplifier with split power supply

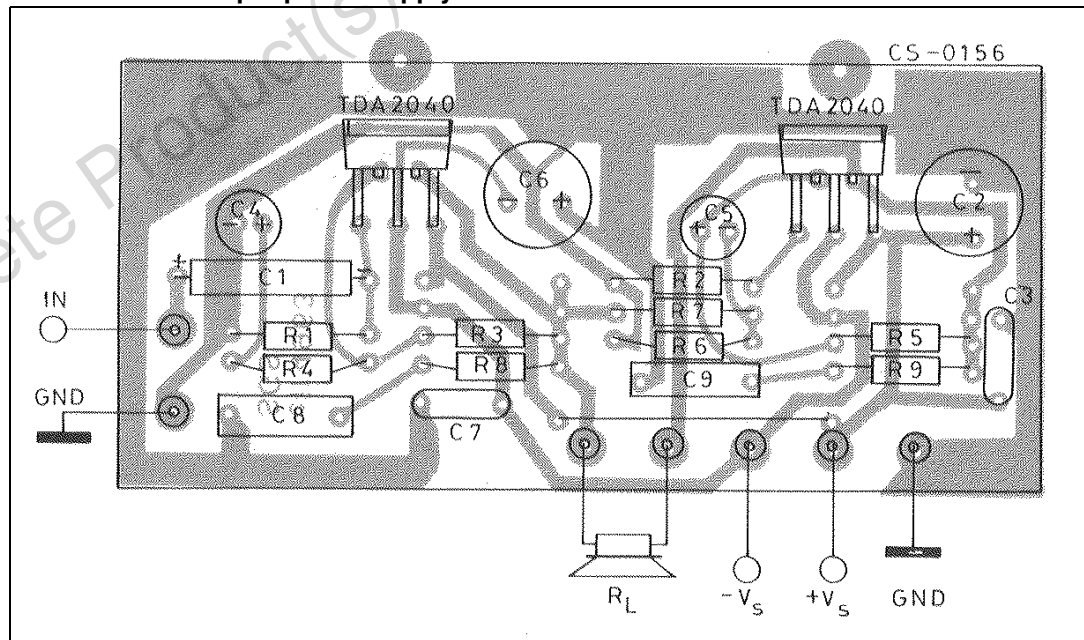

Figure 19. Two-way hi-fi system with active crossover

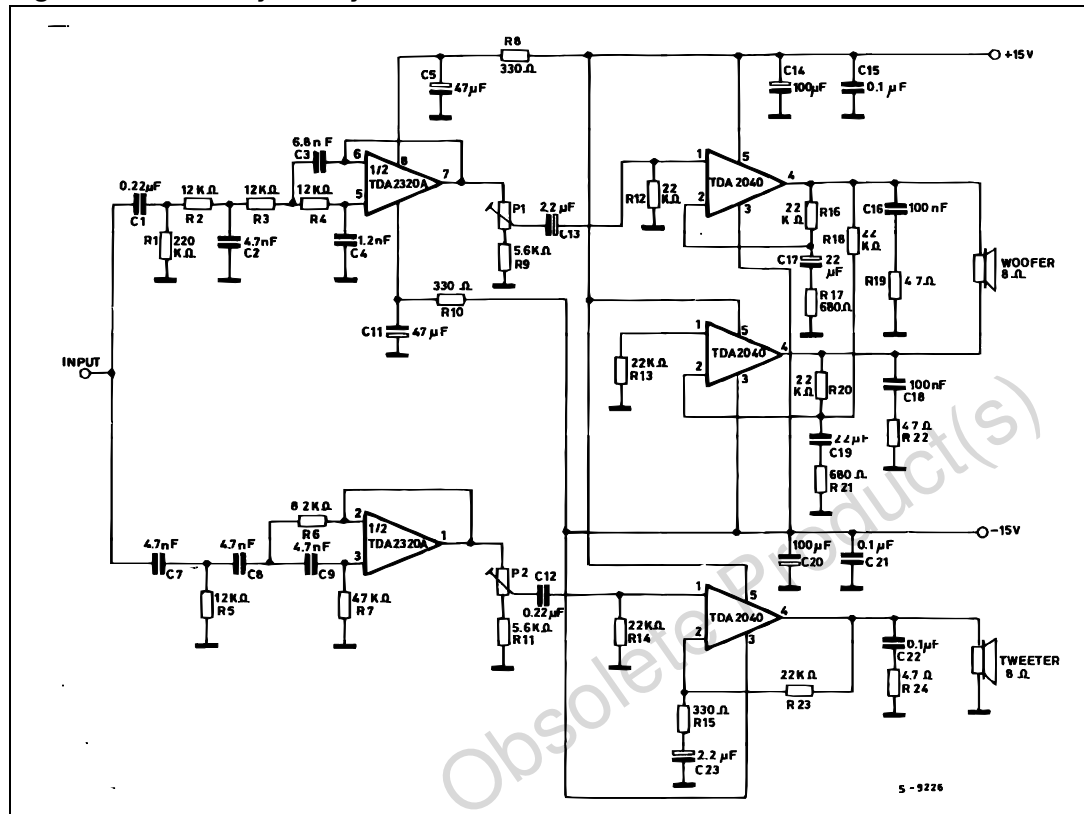
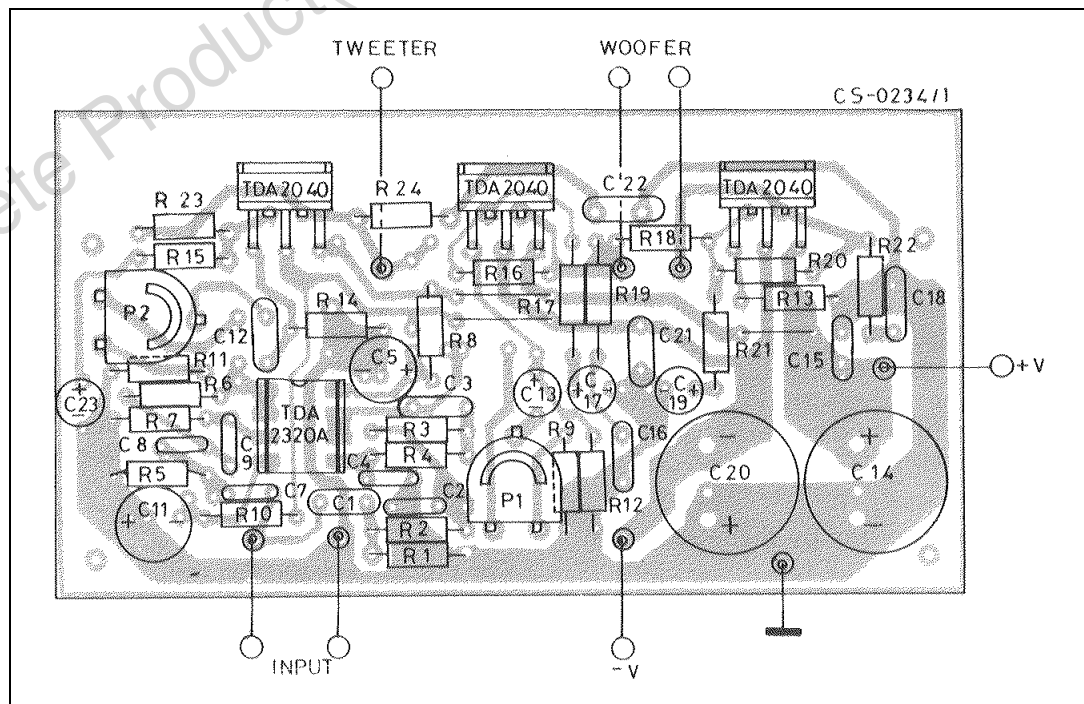

Figure 20. PCB and components layout for the circuit of the two-way hi-fi system with active crossover



3.2 Multiway speaker systems and active boxes

Multiway loudspeaker systems provide the best possible acoustic performance since each loudspeaker is specially designed and optimized to handle a limited range of frequencies. Commonly, these loudspeaker systems divide the audio spectrum into two, three or four bands.

Figure 21. Frequency response

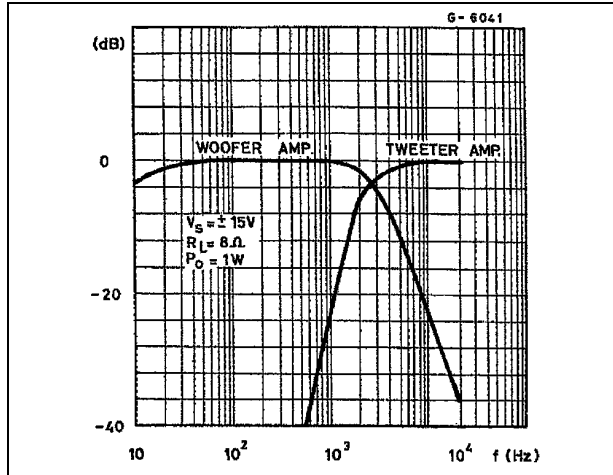
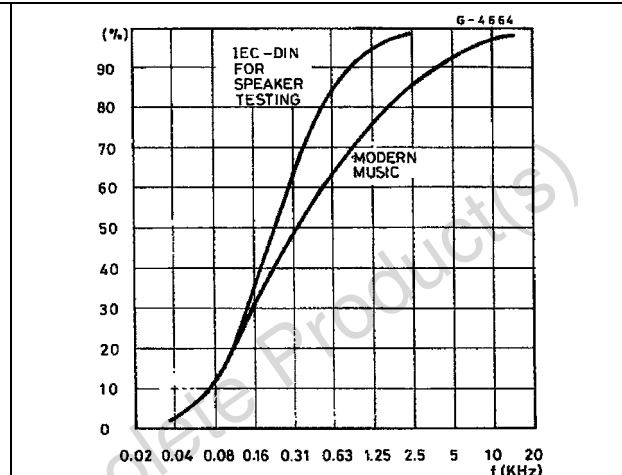

Figure 22. Power distribution vs. frequency



To maintain a flat frequency response over the hi-fi audio range the bands covered by each loudspeaker must overlap slightly. Any imbalance between the loudspeakers produces unacceptable results, therefore, it is important to ensure that each unit generates the correct amount of acoustic energy for its segment of the audio spectrum. In this respect it is also important to know the energy distribution of the music spectrum (see [Figure 22](#)) in order to determine the cutoff frequencies of the crossover filters. As an example, a 100-W three-way system with crossover frequencies of 400 Hz and 3 kHz would require 50 W for the woofer, 35 W for the midrange unit and 15 W for the tweeter.

Both active and passive filters can be used for crossovers but today active filters cost significantly less than a good passive filter using air-cored inductors and non-electrolytic capacitors. In addition, active filters do not suffer from the typical defects of passive filters:

- power loss
- increased impedance seen by the loudspeaker (lower damping)
- difficulty of precise design due to variable loudspeaker impedance

Obviously, active crossovers can only be used if a power amplifier is provided for each drive unit. This makes it particularly interesting and economically sound to use monolithic power amplifiers.

In some applications, complex filters are not really necessary and simple RC low-pass and high-pass networks (6 dB/octave) can be recommended. The results obtained are excellent because this is the best type of audio filter and the only one free from phase and transient distortion. The rather poor out-of-band attenuation of single RC filters means that the loudspeaker must operate linearly well beyond the crossover frequency to avoid distortion.

Figure 23. Active power filter

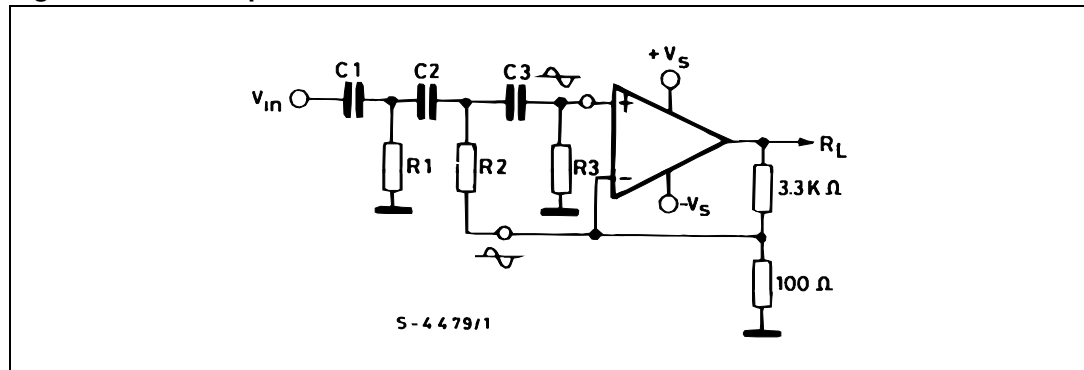

A more effective solution, named "Active Power Filter" by STMicroelectronics, is shown in [Figure 23](#). The proposed circuit can be realized by combined power amplifiers and 12-dB/octave or 18-dB/octave high-pass or low-pass filters.

The component values calculated for $f_c = 900\text{Hz}$ using a Bessel 3rd order Sallen and Key structure are:

- $C1 = C2 = C3 = 22 \text{ nF}$
- $R1 = 8.2 \text{ k}\Omega$
- $R2 = 5.6 \text{ k}\Omega$
- $R3 = 33 \text{ k}\Omega$

In the block diagram of [Figure 24](#) is represented an active loudspeaker system completely realized using power integrated circuit, rather than the traditional discrete transistors on hybrids, very high quality is obtained by driving the audio spectrum into three bands using active crossovers (TDA2320A) and a separate amplifier and loudspeakers for each band. A modern subwoofer/midrange/tweeter solution is used.

Figure 24. High-power active loudspeaker system using TDA2030A and TDA2040

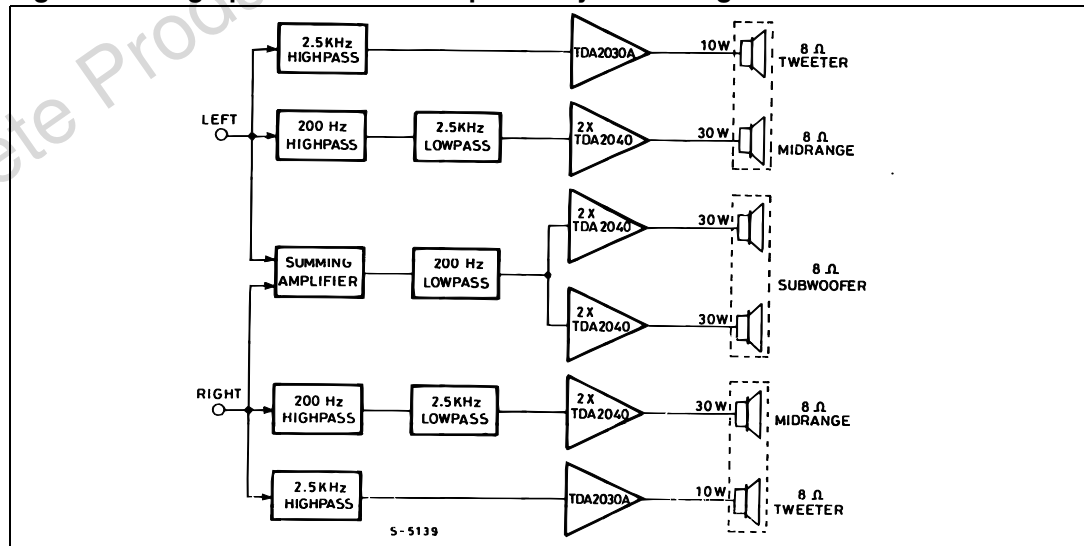

3.3 Practical considerations

3.3.1 Printed circuit board

The layout shown in [Figure 14](#) should be adopted by the designers. If different layouts are used, the ground points of input 1 and input 2 must be well decoupled from the ground return of the output in which a high current flows.

3.3.2 Assembly suggestion

No electrical isolation is needed between the package and the heatsink with single supply voltage configuration.

3.3.3 Application suggestions

The recommended values of the components are those shown in the application circuit of [Figure 13](#). However, if different values are chosen then the following table can be helpful.

Table 5. Variations from recommended values

Component	Recommended value	Purpose	Larger than recommended value	Smaller than recommended value
R1	22 k Ω	Non-inverting input biasing	Increase in input impedance	Decrease in input impedance
R2	680 Ω	Closed-loop gain setting	Decrease in gain ⁽¹⁾	Increase in gain
R3	22 k Ω	Closed-loop gain setting	Increase in gain	Decrease in gain ⁽¹⁾
R4	4.7 Ω	Frequency stability	Danger of oscillation at high frequencies with inductive loads	-
C1	1 μ F	Input DC decoupling	-	Increase in low-frequency cut-off
C2	22 μ F	Inverting DC decoupling	-	Increase in low-frequency cut-off
C3, C4	0.1 μ F	Supply voltage bypass	-	Danger of oscillation
C5, C6	220 μ F	Supply voltage bypass	-	Danger of oscillation
C7	0.1 μ F	Frequency stability	-	Danger of oscillation

1. The value of closed loop gain must be higher than 24 dB

4 Package mechanical data

Figure 25. Pentawatt V outline drawing

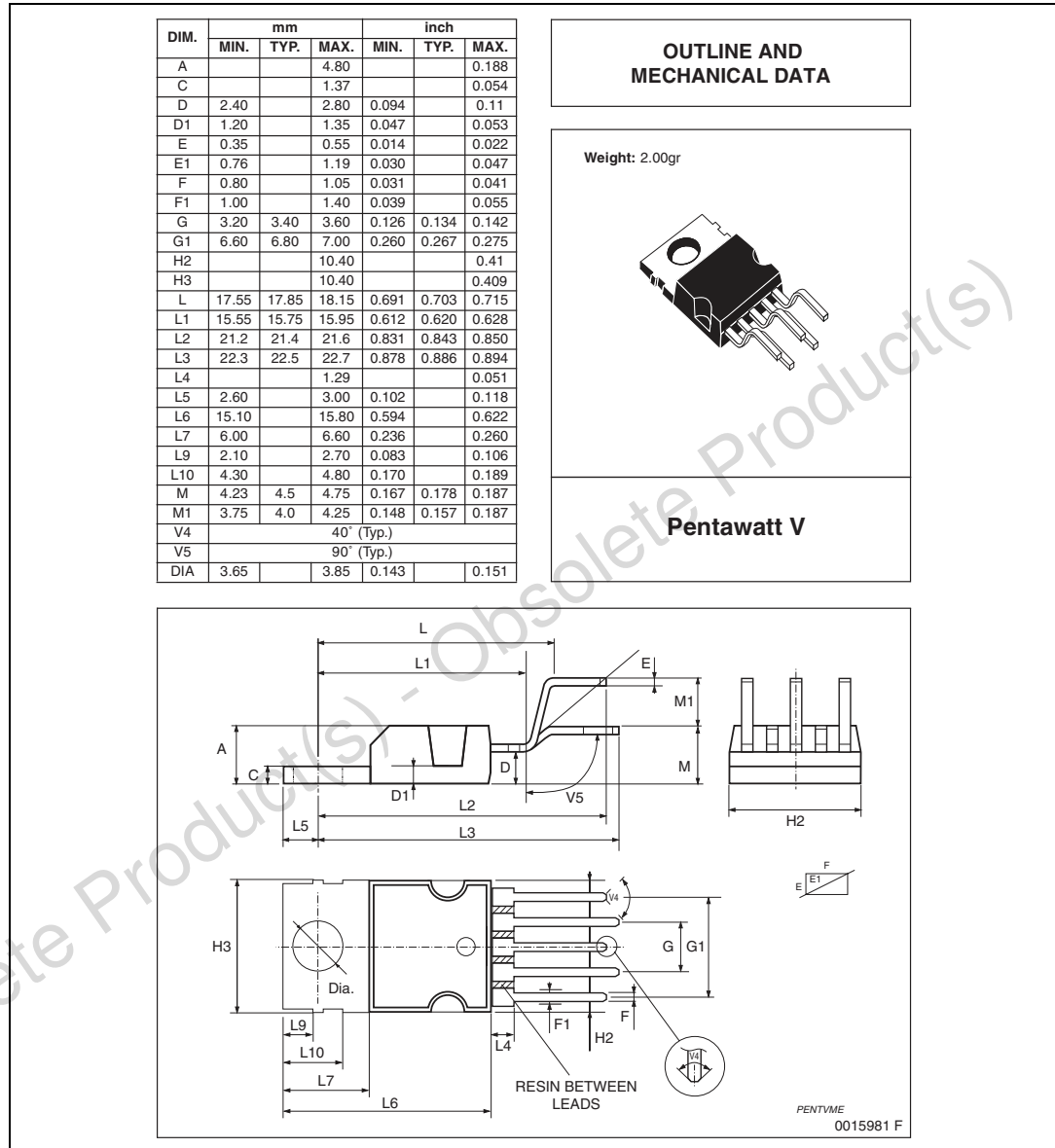

In order to meet environmental requirements, ST offers these devices in different grades of ECOPACK® packages, depending on their level of environmental compliance. ECOPACK® specifications, grade definitions and product status are available at: www.st.com. ECOPACK® is an ST trademark.

5 Revision history

Table 6. Document revision history

Date	Revision	Changes
Apr-2003	3	Changes not recorded
28-Oct-2010	4	Added features list on page 1 Updated minimum supply voltage to ± 4.5 V in Table 4 on page 4 Corrected the title of Figure 15 on page 8 Updated presentation
16-Jun-2011	5	Removed minimum value from Pentawatt (vertical) package dimension H3 (Figure 25); minor textual changes.
17-Jul-2012	6	Updated output power throughout datasheet (title, Features , Description , Table 4).

Please Read Carefully:

Information in this document is provided solely in connection with ST products. STMicroelectronics NV and its subsidiaries ("ST") reserve the right to make changes, corrections, modifications or improvements, to this document, and the products and services described herein at any time, without notice.

All ST products are sold pursuant to ST's terms and conditions of sale.

Purchasers are solely responsible for the choice, selection and use of the ST products and services described herein, and ST assumes no liability whatsoever relating to the choice, selection or use of the ST products and services described herein.

No license, express or implied, by estoppel or otherwise, to any intellectual property rights is granted under this document. If any part of this document refers to any third party products or services it shall not be deemed a license grant by ST for the use of such third party products or services, or any intellectual property contained therein or considered as a warranty covering the use in any manner whatsoever of such third party products or services or any intellectual property contained therein.

UNLESS OTHERWISE SET FORTH IN ST'S TERMS AND CONDITIONS OF SALE ST DISCLAIMS ANY EXPRESS OR IMPLIED WARRANTY WITH RESPECT TO THE USE AND/OR SALE OF ST PRODUCTS INCLUDING WITHOUT LIMITATION IMPLIED WARRANTIES OF MERCHANTABILITY, FITNESS FOR A PARTICULAR PURPOSE (AND THEIR EQUIVALENTS UNDER THE LAWS OF ANY JURISDICTION), OR INFRINGEMENT OF ANY PATENT, COPYRIGHT OR OTHER INTELLECTUAL PROPERTY RIGHT.

UNLESS EXPRESSLY APPROVED IN WRITING BY TWO AUTHORIZED ST REPRESENTATIVES, ST PRODUCTS ARE NOT RECOMMENDED, AUTHORIZED OR WARRANTED FOR USE IN MILITARY, AIR CRAFT, SPACE, LIFE SAVING, OR LIFE SUSTAINING APPLICATIONS, NOR IN PRODUCTS OR SYSTEMS WHERE FAILURE OR MALFUNCTION MAY RESULT IN PERSONAL INJURY, DEATH, OR SEVERE PROPERTY OR ENVIRONMENTAL DAMAGE. ST PRODUCTS WHICH ARE NOT SPECIFIED AS "AUTOMOTIVE GRADE" MAY ONLY BE USED IN AUTOMOTIVE APPLICATIONS AT USER'S OWN RISK.

Resale of ST products with provisions different from the statements and/or technical features set forth in this document shall immediately void any warranty granted by ST for the ST product or service described herein and shall not create or extend in any manner whatsoever, any liability of ST.

ST and the ST logo are trademarks or registered trademarks of ST in various countries.

Information in this document supersedes and replaces all information previously supplied.

The ST logo is a registered trademark of STMicroelectronics. All other names are the property of their respective owners.

© 2012 STMicroelectronics - All rights reserved

STMicroelectronics group of companies

Australia - Belgium - Brazil - Canada - China - Czech Republic - Finland - France - Germany - Hong Kong - India - Israel - Italy - Japan - Malaysia - Malta - Morocco - Philippines - Singapore - Spain - Sweden - Switzerland - United Kingdom - United States of America

www.st.com