

GEAR MOTOR DATA:

1	Rated Voltage	6.0 VDC	2	No Load Current	120mA MAX
3	No Load Speed	11±15% rpm	4	Rated Torque	1094gf.cm
5	Rated Current	0.2A MAX	6	Rated Speed	10±15%rpm
7	Stall Torque	5000gf.cm	8	Stall Current	0.6A MAX
9	Gear Ratio	864:1	10	No Load Noise	60 db

Test Method: Detector with sponge to gearbox side at 10cm in ambient noise under 32dB.

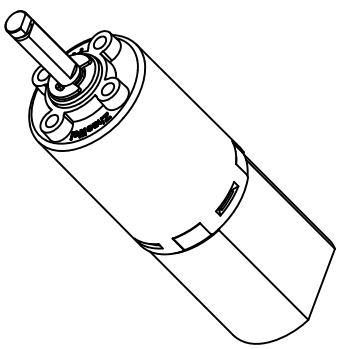

- TECHNICAL REQUIREMENTS:**
1. No defects such as crack, scratch, burr and deformation.
  2. Dimensions in bracket for reference.
  3. No abnormal noise in testing.
  4. RoHS compliant.

产品名称	Φ16行星齿轮箱		产品代码	ZMPD016016-864	
客户名称			共 1 张	版本	A
设计	陶政邦	2015-04-08	第 1 张	比例	1:1

符合《ROHS相关禁止物质标准》

