



MAINTENANCE AND USER'S MANUAL

**IMPORT-EXPORT
AKTIVE-REACTIVE
SINGLE PHASE ELECTRONIC
ELECTRICITY METERS**

LSM SERIES

LSM10

MANUFACTURER INFORMATION:

LUNA ELEKTRİK ELEKTRONİK SAN. VE TİC. A.Ş.

10001 Str. No:9 Atatürk O.S.B.

35620 Çiğli / İzmir - TÜRKİYE

Tel: +90 232 472 15 45 Fax: +90 232 472 15 50

www.lunatr.com

SERVICES:

Main Technical Service:

LUNA ELEKTRİK ELEKTRONİK SAN. VE TİC. A.Ş.

10001 Str. No:9 Atatürk O.S.B.

35620 Çiğli / İzmir - TÜRKİYE

Tel: +90 232 472 15 45 Fax: +90 232 472 15 50

ATTENTION

READ THE MANUAL CAREFULLY BEFORE OPERATING THE METER.

The assembly of LSM Series Active-Reactive Single Phase meter should be in accordance with to the connection schemes in the manual and executed by authorized personnel. Otherwise, the warranty does not cover any damage costs to the meter.

The compatibility of the meter to the energy lines and facility where assembly takes place should be verified by authorized personnel. Incorrect meter choice and connection damages the meter. Such meters are out of warranty cover.

LUNA Electronic Electricity Active Meters have five (5) year warranty covering any manufacturing defects. In case of intervention by any individual or organization apart from authorized personnel defined by Central Meter Calibration Station, the warranty will be void.

Defects due to misuse of determined technical features in user's manual of LUNA Electronic Electricity Meters (usage out of range set in the manual) are not considered under cover of warranty.

LSM Series Active-Reactive Multi Tariff Single Phase Electronic Electricity Meters are, Hardware and software of, designed by R&D department of LUNA and manufactured by itself.

LSM Series Active-Reactive Single Phase Electronic Electricity Meters satisfies the requirements of 2004/22/AT Measuring Tool Article, EN 50470 standards.

LUNA ELEKTRIK ELEKTRONIK SAN. and TIC. A.S has no liability if the operating instructions in the manual are not complied.

In the following cases warranty will be void

Warranty is void if seals of LUNA ELEKTRIK ELEKTRONIK SAN. and TIC. A.S are broken.

Damages to the mechanical and electrical structure of the meter due to external interference are out of warranty cover.

All physical damage during the mounting of the meter (fractures, cracks) are out of warranty cover.

All damages caused during mounting by unauthorized personnel is out of warranty cover.

INTRODUCTION

General Safety Precautions

SEALS AND SCREWS OF ELECTRONIC ELECTRICITY METERS, SEALED BY LUNA ELEKTRIK ELEKTRONIK SAN. and TIC. A.S AND ELECTRIC DISTRIBUTION COMPANY, MUST BY NO MEANS BE OPENED, EXCEPT FROM AUTHORIZED PERSONNEL, AFTER BEING ENERGIZED.

- The mounting of the meter should be executed by expert personnel provided with technical information in accordance with connection schemes and safety regulations in the manual.
- There's danger of electric shock in live electronic electricity meters connector covers and near the electricity board where connection is made.
- Energy should be turned off during mounting and demounting of the meter.
- For longer life and smooth usage of the mounted Electronic Electricity Meter board regulations defined by the electricity distribution company must be complied. Humidity, direct exposure to sunlight, rain and cold should be avoided.
- As electricity measurement are performed using electronic components, to avoid any damage, no physical impact should be applied to the meter.
- Despite having OUTDOOR feature, LSM10 Active-Reactive Single Phase Electronic Electricity meters should by no means be exposed to immersion. Outer surfaces of the meters should be cleaned by solvents.
- All meters are calibrated in accordance with defined articles and regulations. No other routine maintenance by the client is necessary.
- Meters by no means should be opened by the user and intervened for repair.
- Optical port interface on the meters should only be used for data transfer set by electric distribution company regulations.
- Although humidity and temperature are not a concern during storage, it is not advised to keep the meters at maximum values of these parameters.

1. GENERAL FEATURES

1.1. Metrology

LSM Series Active-Reactive Electric Electricity Meters can measure and record active import energy. Voltage and current measurement, and energy calculation is carried out by the microprocessor in the meter. If energy is in reverse direction, the import meter takes its absolute value and assumes it as positive. The import-export meter, however, measures and stores the data of import and export energy separately. Additionally, reactive energy can also be measured.

1.2. Software Version

Meter Software version can be readout from e-meter via OBIS code 96.97.

1.3. Tariffs

1.3.1. Main Tariffs and Tariff Intervals

LSM Series Active-Reactive Electric Electricity Meters are able to split day time as import and export, and store measurement data for 4 tariffs and 8 billing periods for weekdays, Saturdays and Sundays separately. The measured energy is added to both total tariff (T) and the corresponding tariff (T1, T2, T3 or T4). The tariff information can be viewed on LCD or read out using the OBIS codes from 1.8.0 to 1.8.4 (import) and from 2.8.0 to 2.8.4 (export**) in the format: (000000.000*kWh)

1.8.0 and 2.8.0 gives the total tariff (T) information and 1.8.1,...,1.8.4 and 2.8.1,..., 2.8.4 gives T1, T2, T3, T4 information of import energy and export energy respectively.

At the end of each month, T, T1, T2, T3 and T4 data is automatically stored in the non-volatile memory of the meter as the previous month's record. Last 24 months' data is always stored in the non-volatile memory automatically. The previous months' tariff data can be read using OBIS codes from 1.8.1*1 to 1.8.4*24 (import) and from 2.8.1*1 to 2.8.4*24 (export**). For instance, 1.8.1*1 OBIS code corresponds to the previous month's Import Tariff 1 record; the last 24 month's Import T1 parameter can be read with OBIS codes from 1.8.1*1 to 1.8.1*24.

Tariff intervals are pre-programmed as follows

Tariff 1: 06:00 - 17:00

Tariff 2: 17:00 - 22:00

Tariff 3: 22:00 - 06:00

Tariff 4: -

Automatic daylight saving is active by default. It can be disabled using the OBIS code 96.98(10) and re-enabled with 96.98(00).

In case extra intervals or tariff changes are needed, it can only be performed by authorized personnel using optical port interface.

1.3.2. Advanced Tariff (Optional)

LSM meters optionally have advanced tariffs structure. 8 different tariff profiles can be defined for each day in a week and specified holidays. Likewise, 8 different season profiles can be defined and 4 different

weekly profiles can be defined for seasons. Different tariffs can be assigned for each day in a week. Unlimited holidays can be defined for the next 10 years.

1.3.3. Passive Tariffs (Optional)

Passive tariffs are used in order to change the used tariffs structure after a certain date. LSM meter reading software is used to create and write the passive tariffs structure, in the same format as the active advanced tariffs structure. In addition to the passive tariffs structure, the activation date needs to be written for the passive tariffs to be activated when required. Once the time of activation comes, the passive tariffs are overwritten to the active tariffs in the memory of the meter, and the passive tariffs data and the activation date are deleted.

1.4. Maximum Demand

The maximum demand is stored as the maximum demand of the previous month, at the end of each billing period. Then, this parameter is cleared by the meter. This process is done automatically at the end of month, if the maximum demand is not reset manually within that month. LSM series meters stores the maximum demand and date and time of the maximum demand for the last 24 months. The current value of maximum demand and its date and time can be viewed on LCD or read out using the OBIS codes 1.6.0 (import) and 2.6.0 (export). The previous months' information can be read out with the OBIS codes from 1.6.0*1 to 1.6.0*24 (import) and from 2.6.0*1 to 2.6.0*24 (export). The maximum demand information is read in the following format:

(000.000*kW)(YY-MM-DD,HH:mm)

1.5. Load Profile

LSM meters store the load profile data in its non-volatile memory for the past 90 days with 15 minute period, 180 days for 30 minute period and 360 days for 60 minute period by default. The load profile memory can be extended by request to support storing of over 20 years of load profile data.

The meter recognizes the following format:

<SOH>R5<STX>P1(YYMMDDHHmm;YYMMDDHHmm())<ETX><BCC>

and responds in the following format:

<STX>R5(XX)

(YYYY-MM-DD)(HH:MM)(XXXXXX.XXX*kWh)

(YYYY-MM-DD)(HH:MM)(XXXXXX.XXX*kWh)

...

<ETX><BCC>

1.6. Writing Parameters of the Meter

Authorized personnel can write only the following parameters to the meter using the meter password:

- Meter Date
- Meter Day of the Week
- Meter Time
- Tariff Intervals

- Tariff Hours
- Maximum Demand Period
- Load Profile Period
- Automatic Daylight Saving Parameter
- New Password

Other than the parameters above, none of the meter parameters can be changed in any way.

1.7. RTC

RTC is in compliance with EN 61038 protocol. The maximum time deviation is ± 0.5 second daily.

1.8. Battery Operation

The meter operates with one main battery and optional secondary battery. The battery / batteries provide necessary power supply in case of absence of line power. Battery powered supply allows the meter to be awoken with Menu Button in the absence of phase energy. While the LCD is on, the meter data can be viewed on the LCD, or can be read out using optical port.

The battery condition can be read by OBIS code "96.6.1". The data in the response from the meter is:

96.6.1(0) : battery is empty, 96.6.1(1) : battery level is OK.

1.9. Logs and Info

The meter keeps logs of the following information in its non-volatile memory:

1.9.1. Phase Interruptions

The start and end-time of phase interruptions are stored in the non-volatile memory of the meter. The meter records the date and time of last 10 phase interruptions. The number of total phase interruptions and the total phase-off duration can be read by OBIS code "96.7.1" and 96.77.11 respectively, the date and time information of last 10 phase interruptions can be read by OBIS codes from "96.77.1*1" to "96.77.1*10".

1.9.2. Main Cover and Terminal Cover Openings

The first main cover opening date and time information is stored in the non-volatile memory of the meter. It can be read by OBIS code "96.70". Terminal cover opening date and time of current and past 24 months are recorded in the non-volatile memory. The current information can be read by OBIS code "96.71" and the past information can be read by OBIS codes from "96.71*1" to "96.71*24".

1.9.3. Advanced Terminal Cover Opening Event (Optional)

The last 30 terminal cover opening events in the last month are recorded along with the date and time of occurrence. The current record can be read by 96.91 OBIS code, while the previous month's records are read using 96.91*1,.....,96.97*12 OBIS codes.

1.9.4. RTC Failures

When RTC failure occurred, a clock icon is displayed on the LCD. In this failure condition, the meter only records to T1 tariff. The icon

disappears and the fault is cleared when date and time information is written to the meter. The meter can optionally display a constant message on its screen in this case unless the menu button is pressed and auto scrolling is off.

1.9.5. Magnetic Interventions

The last 10 intervals when magnetic field is applied and the number of magnetic interventions are stored in the non-volatile memory of the meter. The number of magnetic interventions can be read by OBIS code "96.80" and the date and time information of last magnetic interventions can be read by OBIS codes from "96.80*1" to 96.80*10".

1.9.6. Production Date

The production date is stored in the memory and can be read with OBIS code "96.1.3".

1.9.7. Meter Status Recorders

LSM Series Meters have 4 status codes for reading the meter information, errors, warnings and features. The statuses have the following OBIS codes:

F.F.0: Critical Meter Errors

F.F.1: Warnings

F.F.2: Meter Information

F.F.3: Meter Features

Each status has a structure in the form of FFFFFFFFh. One F corresponds to 4 bits in binary and each bit is either 1 or 0. The meaning of each bit which is set is described below:

From right to Left (LSB to MSB):

F F F F F F F F 1111 1111 1111 1111 1111 1111 1111 1111

STATUS0:

1: meter time was/is invalid

1: rtc module error occurred

1: meter is uncalibrated

1: reserved

1: soft reset occurred

1: hard reset occurred

1: reserved

1: meter supply is out of range

1: error in metrology current measurement section

1: error in metrology voltage measurement section

1: communication error with metrology IC

1: fatal metrology error occurred

1: checksum error occurred within consumption data

1: checksum error occurred within 1st backup of consumption data

1: flash memory write error occurred

1: other fatal errors occurred

1: external memory error occurred

1: reserved

1: PLC module error occurred

1: RF module error occurred

1: RS485 port error occurred

1: meter is locked to any intervention

1: reserved

1: reserved

1: extremely high demand value recorded

1: extremely high energy consumption recorded

1: reserved

1: reserved

1: general system error occurred

1: reserved

1: reserved

1: reserved

STATUS1:

1: over voltage is applied on at least one of the phases of the meter currently

1: under voltage is applied on at least one of the phases of the meter currently

1: over current is drawn by the consumer cur-

rently	1: PLC module is connected to the PLC network
1: the current on at least one of the phases is reversed	1: RF module is connected to the RF network
	1: reserved
	1: reserved
1: phase sequence is correct	
1: phase R is on	1: reserved
1: phase S is on	1: reserved
1: phase T is on	1: reserved
	1: reserved
1: phase RST off event started	
1: phase R off event started	1: reserved
1: phase S off event started	1: reserved
1: phase T off event started	1: reserved
	1: reserved
1: active energy limit reached	
1: reactive energy limit reached	1: reserved
1: at least one of the phase currents in the poly-phase meter is unbalanced with respect to the average current of all phases	1: reserved
	1: reserved
1: at least one of the phase voltages in the poly-phase meter is unbalanced with respect to the average voltage of all phases	1: reserved
1: 00 = battery 1 empty, 01 = battery 1 level low, 11 = battery 1 level good	
1:	
1: 00 = battery 1 empty, 01 = battery 1 level low, 11 = battery 1 level good	
1:	1: Latching Relay is supported
	1: EEPROM is supported
1: maximum demand limit exceeded	1: SPI flash is supported
1: reactive energy consumption limit exceeded	1: Software upgrade is not supported
1: considerable amount of neutral current is drawn	
1: reserved	1: Export energy measurement feature is enabled
	1: Reactive energy measurement is supported
1: tariff settings are written to the meter	1: Load Profile recording is supported
1: date/time is written to the meter	1: reserved
1: other parameter is written to the meter	
1: reserved	1: LCD backlight is supported
1: reserved	1: Advanced phase interruptions feature is supported.
1: reserved	1: Holiday tariff feature is supported
1: reserved	1: LCD sub-menu is supported
STATUS2:	
1: parameter(s) written to the meter locally	1: Advanced log feature is supported
1: parameter(s) written to the meter remotely	1: DLMS communication is supported
1: meter time synchronized locally	1: If 1, 10000 impulse mode; if 0, 1000 impulse mode
1: meter time synchronized remotely	1: reserved
1: Main cover of the meter is currently open	
1: Main cover of the meter has been opened	1: reserved
1: Terminal cover of the meter is currently open	1: reserved
1: Terminal cover of the meter has been opened	1: reserved
	1: reserved
1: Strong magnetic field is currently being applied	1: Over and under voltage detection are supported
1: Strong magnetic field has been applied	1: Over current detection is supported
1: reserved	1: Magnetic tamper detection is supported
1: reserved	1: Daylight saving time feature is enabled
1: Latching relay is connected	
1: Latching relay status has been changed	1: reserved
1: Latching relay error occurred	1: reserved
1: reserved	1: reserved
	1: reserved

The statuses can also be easily read with the LSM meter reading software using the Status tab. After reading the statuses, the bits which are set appear in bold on the left with their meanings. **Note that, some of the status bits may not be available in all meter models.**

1.9.8. Meter Logs

Meter keeps logs of various errors and events in its non-volatile memory. These logs can be read using 96.75*1(00),..., 96.75*150(00) OBIS codes. The log data is in (YY-MM-DD, hh:mm:ss |<error code>) format.

The complete logs can be read by asking the meter 96.75*X(00) OBIS code starting with X as 1, and incrementing X until an empty log data (-----,--:--:--|--) is received or X reaches 150. The basic error codes are as follows:

- 01: Current energy consumption values inconsistent
- 02: Extreme energy consumption value measured
- 06: Meter is initialized
- 07: Hard reset occurred
- 08: Soft reset occurred
- 12: EEPROM write error
- 16: Meter is programmed
- 19: RF module malfunctioned
- 20: PLC module malfunctioned
- 24: Battery 1 level dropped to critical level
- 25: Battery 2 level dropped to critical level
- 33: Error reading time backup
- 35: Load profile structure error
- 38: RTC module malfunctioned
- 40: Flash memory write error
- 50: Meter firmware upgraded
- 51: SPI Flash write error
- 52: Total energy consumption value increased too much in a short time.

1.10. Optional Integrated Features

1.10.1. Reactive Energy Measurement

LSM series meters have an optional feature that allows measuring of reactive energy. The current inductive (5.8.0) and capacitive (8.8.0) energy data, and the consumption values of the past 24 months are stored in the meter. The inductive and capacitive energy data of the past 24 months can be read using the OBIS codes of 5.8.0*1, 5.8.0*2, ..., 5.8.0*24, and 8.8.0*1, 8.8.0*2, ..., 8.8.0*24 respectively.

1.10.2. Import-Export Energy Measurement

LSM series meters can optionally measure energy bi-directionally. The measured export energy is recorded apart from the import tariffs and added to the total export active tariff -T and the corresponding export tariff from -T1, -T2, -T3, -T4. The export reactive consumptions are also recorded separately from the import reactive consumptions

and added to the -Ri, -Rc export reactive tariffs. The export energy information can be viewed on the LCD following the related OBIS codes (2.8.0, ..., 2.8.4, 7.8.0, 6.8.0). Export -T, -T1, -T2, -T3, -T4, -Ri (inductive), -Rc (capacitive) consumptions have OBIS codes of 2.8.0, 2.8.1, 2.8.2, 2.8.3, 2.8.4, 7.8.0, 6.8.0 respectively. The export measurement values are displayed with a negative (-) sign to the left (-T, -T1, -T2, -T3, -T4, -Ri, -Rc).

Export measurement feature can be turned on by writing 1 or turned off by writing 0 to 96.74.18 OBIS code. After export feature is disabled or enabled, the past load profile data is erased. If export feature is enabled, import and export consumptions are recorded; however, if export feature is disabled, only the import consumption is recorded, which significantly increases the maximum number of records the load profile can hold compared to import-export.

1.10.3. RS485 Communication Port

In case there is only one meter connected to the data line, the meter can be readout using the format “/?!CRLF” via RS485 protocol. On the other hand, if multiple meters are connected to the same data line, the meters can be read individually using the format “/?XXXXXXXX!CRLF” where XXXXXXXX is the serial number of the meter to be readout.

1.11.4. DLMS Communication

The meter supports DLMS Communication over communication ports.



1.10.5. PLC Communication

The meter can have an integrated PLC module to support PLC communication. Then, it can be readout and controlled using a Data Concentrator(DC) and from LUNA Metrum remotely.

The PLC module uses CENELEC A band and DCSK modulation for power line communication. It supports communication speed of up to 2.5kbps.

No setup or connection is required for PLC communication on the meter side.

1.10.6. RF Communication

The meter can have an integrated RF module to support RF communication. Then, it can be readout and controlled using a Data Concentrator(DC) or a GSM Modem and from LUNA Metrum remotely.

The RF module uses 868MHz ISM band and a custom protocol by LUNA meters for communication. It supports communication speed of up to 200kbps.

No setup or connection is required for RF communication on the meter side.

1.10.7. GPRS Communication Module

There is optional GSM Modem present in the meter. For GSM Modem features please refer to GSM Modem User Manual.

1.10.8. Calendar Support

LSM meters support Gregorian, Hijri and Persian calendars. All records and calendar events are stored according to the calendar type. Default calendar of the meter is Gregorian.

1.10.9. kWh Limitation

If the meter includes this feature, it is activated by default. It can be disabled by writing 0 or re-activated by writing 1 to 96.74.22 OBIS code. When the subscriber reaches the monthly consumption limit defined in 96.73.30 OBIS code, the subscriber's electricity will be disconnected if the feature is enabled. If the Consumption Limitation Repeat (96.74.24) feature is enabled (value 1), the electricity can be reconnected for Allowed Button Connect Count (96.73.33) times by pushing the menu button of the meter. The limit is reset at the end of each month.

1.10.10. LCD Backlight

The backlight is turned on when menu button is pressed or optionally on read or write attempt on the meter if electricity is available.

1.10.11. Latching Relay

The electricity of the meter can be connected/disconnected immediately or at a certain time, remotely or locally by the latching relay inside the meter. The latching relay state can be changed by the below OBIS code and data through optical port/RS485/smart communication module.

96.74(0X)(YY-MM-DD)(000000)

Operating date Optional Operator ID Optional

where X = 0 for connect or X = 1 for disconnect operation. Entering an operator ID is optional. Additionally, if the latching relay is to be connected immediately, there is no need to enter an action time while writing the OBIS; while, a date-time of operation can be written as in the above format if needed.

1.10.12. Non-Volatile Memory

For higher memory requirements the meter may have additional non-volatile memory IC.

1.10.13. Buzzer

It is used for audible alarm functions of the meter. For example if meter terminal cover is removed, meter can produce alarm tone for a defined period of time if this feature is turned on.

1.10.14. Over- Under Voltage Record

LSM series meters can optionally support detection and recording of over voltage and under voltage events. When instant voltage exceeds the defined over voltage parameter (96.73.20) value or falls below the defined under voltage parameter (96.73.21) value, over voltage or under voltage event records the beginning time of the respective event. When the over or under voltage condition ends, the end time of

the respective event is recorded and the counter and total duration of that event are updated. The start-end time of over voltage and under voltage events can be read using the OBIS codes of 96.77.30*1,...,12 and 96.77.40*1,...,12 respectively. The total number and duration of over voltage events can be read with OBIS codes of 96.77.30 and 96.77.31, whereas those of under voltage events can be read using the OBIS codes of 96.77.40 and 76.77.41 respectively.

All of the Over Voltage and Under Voltage parameters can be changed through Features tab of the meter reading software. The parameters related to over and under voltage events that can be changed are as follows:

val_ov(96.73.20): The value of voltage over which over-voltage is detected

val_uv(96.73.21): The value of voltage below which under-voltage is detected

ouv_record_delay(96.73.24): the minimum duration of an over/under voltage event to start or end recording.

1.10.15. Over Current Record

LSM series meters can optionally support detection and recording of over current events. When instant current exceeds the defined over current parameter (96.73.22) value, over current event records the beginning time of the event. When the over current condition ends, the end time of the event is recorded and the counter and total duration of the event are updated. The start-end time of over current events can be read using the OBIS codes of 96.77.50*1,...,12. The total number and duration of over current events can be read with OBIS codes of 96.77.50 and 96.77.51 respectively.

All of the Over Current parameters can be changed through Features tab of the meter reading software. The parameters related to over current events that can be changed are as follows:

val_oi(96.73.22): The value of current over which over current is detected

oi_record_delay(96.73.24): the minimum duration of an over current event to start or end recording.

1.10.16. Auto Disconnect LR on Over/Under Voltage

LSM Series meters can optionally support disconnecting the latching relay of the meter in case over/under voltage occurs. If this feature is supported in the meter, **feat_lr_auto_ouv_err(96.74.20)** OBIS code can be read or written to. The descriptions of the related OBIS codes for this feature are as below:

feat_lr_auto_ouv_err(96.74.20): if 0, auto disconnecting on over/under voltage is disabled; if 1, auto disconnects on over/under voltage and connects back at nominal voltage for counter_lr_auto_ouv(96.73.23) times and then doesn't reconnect after the next disconnection on over/under voltage; if 2, auto disconnects on over/under voltage and connects back at nominal voltage without limit; if 3, auto disconnects on over/under voltage and connects back at nominal voltage for counter_lr_auto_ouv (96.73.23) times and then doesn't

disconnect after that.

counter_lr_auto_ouv(96.73.23): the number of times the meter is disconnected or connected if feat_lr_auto_ouv_err (96.74.20) is 1 or 3

dur_lr_auto_ouv_err(96.73.26): the event duration after which the latching-relay of the meter will be disconnected if feat_lr_auto_ouv_err(96.74.20) is not 0 or limit is not reached in limiting modes (1 and 3)

feat_lr_reset_limit_endofmonth(96.74.21): If this feature is enabled (value 1), the number of times the meter was disconnected/connected is reset and the blocking of Lr is removed at the end of every month. Additionally, if a manual disconnection (by optical port or remotely) is issued, the over/under voltage event cannot reconnect the Lr until the end of the month if this feature is enabled.

1.10.17. Auto Disconnect LR on Over Current (Consumption Limitation)

LSM Series meters can optionally support disconnecting the latching relay of the meter in case over current occurs. If this feature is supported in the meter, feat_lr_auto_oi_err(96.74.21) OBIS code can be read or written to. The descriptions of the related OBIS codes for this feature are as below:

feat_lr_auto_oi_err(96.74.21): if 0, auto disconnecting on over current is disabled; if 1, auto disconnects on over current and connects back after dur_lr_off(96.73.29) seconds for counter_lr_auto_oi(96.73.37) times and then doesn't reconnect after the next disconnection on over current; if 2, auto disconnects on over current and connects back after dur_lr_off(96.73.29) seconds without limit; if 3, auto disconnects on over current and connects back after dur_lr_off(96.73.29) seconds for counter_lr_auto_oi(96.73.37) times and then doesn't disconnect after that.

counter_lr_auto_oi(96.73.37): the number of times the meter is disconnected or connected if feat_lr_auto_oi_err(96.74.21) is 1 or 3

dur_lr_auto_oi_err(96.73.27): the event duration after which the latching-relay of the meter will be disconnected if feat_lr_auto_oi_err(96.74.21) is not 0 or limit is not reached in limiting modes (1 and 3)

feat_lr_reset_limit_endofmonth(96.74.21): If this feature is enabled (value 1), the number of times the meter was disconnected/connected is reset and the blocking of Lr is removed at the end of every month. Additionally, if a manual connection (by optical port or remotely) is issued, the over current event doesn't disconnect the Lr until the end of the month; if a manual disconnection is issued, the Lr stays disconnected forever until the next manual connection command if this feature is enabled.

1.10.18. Auto Disconnect on Very High Voltage

If this feature is supported in the meter, 96.74.26 OBIS code can be read or written to. If this feature is supported and enabled in the meter (value 1), when more than 320V is applied to the monophase meter for 3 seconds, the meter disconnects its latching relay to protect the consumer's devices. It reconnects its latching relay if less than 320V is applied to the monophase meter for 3 seconds.

This feature works independently from Over/Under Voltage Record feature. Moreover, this feature overrides Auto Disconnect LR on Over/Under Voltage (96.74.20) feature. In other words, if both features (96.74.26 and 96.74.20) are enabled, 96.74.26 feature will be used; whereas, if 96.74.26 is disabled (value 0) and 96.74.20 is enabled (value 1), 96.74.20 feature will be used.

1.10.19. Meter Write Logs

LSM series meters can keep logs of the writings to the meter, along with their date-time, password level, operator id and OBIS code including its data. The writing log is read in (YY-MM-DD,

hh:mm|A1|000000|<OBIS code with data>) format, where A is the password level (0,1,2).

The complete writing logs can be read by asking the meter 96.92*X(00) OBIS code starting with X as 1, and incrementing X until an empty writing log data (00-00-00,00:00|00|000000) is received.

1.10.20. Programmable LCD

LSM series meters have an optional feature that allows configuration of lcd pages as desired. The customer can select which OBIS code values to display on LCD in which order. The Programmable LCD tab in LSM GUI software is used to define the lcd pages by entering their OBIS codes in desired order, separately for main menu and sub menu.

Contact the manufacturer to request non-standard OBIS codes to be displayable on LCD.

1.10.21. Modifiable LCD Fraction

The number of integers and decimals displayed on LCD for consumption data can optionally be modified using the OBIS code 96.90.7(XY), where X is number of integers and Y is number of decimals to display.

1.10.22. Relay Output

A relay output is available if requested. It can be opened or closed by 96.74.1 obis code. Relay has two output connector on meter cover. These are NO or NC and COMMON relay pins. If relay is switched on then output connectors will be in closed or open state. The relay has two output connectors on meter cover as NO and COMMON relay pins. The relay can be switched on or off by writing 1 or 0 to 96.74.1 OBIS code, respectively.

1.10.23. Neutral Measurement

LSM series meters can optionally support detection and recording of neutral current events. When the magnitude of the neutral current is measured at least 0.5A greater than the magnitude of the vectorial sum of phase, neutral current event records its beginning time and the neutral current miss-match icon 'n' is blinked on the LCD of the meter during the event. When the neutral current event ends, its end time is recorded and its counter is incremented. The start-end time of neutral current events can be read using the OBIS codes of 96.77.9*1,....,10. The total number of neutral current events can be read with OBIS code of 96.77.60.

1.10.24. GEN Module

LSM Meters optionally include an input for connecting 220V generator output to detect if generator is active or not. When generator is active, the meter records the consumption in the generator tariff (T1); when generator is not working, the meter records the consumption in standard tariff (T4). LSM meters with prepayment feature and generator input have support for separate credits and unit prices for generator and standard tariffs. When the generator is active, the meter uses its generator credit with generator unit price. If the generator credit of the meter is empty and the generator is active, then the meter disconnects electricity of the subscriber. Similarly, if generator is not active, the meter uses its standard credit and standard unit price. If the standard credit is empty and the generator is not working, the meter disconnects electricity of the subscriber.

2. OPERATING ELEMENTS

2.1. LCD

The meter displays energy data and other parameters on its 5-integer (optionally 6 integer), 3-decimal digit LCD screen. It also displays symbols for the notifications described above. Detailed information about LCD can be found in the LCD Screen Information section.

2.2. Menu Button

The LCD menus can be browsed by pressing the menu button.

2.3. Active Power Consumption LED

Each light pulse indicates 1 Wh active power consumption.

2.4. Reactive Power Consumption LED (On Active-Reactive Model)

Each light pulse indicates 1 VARh reactive power consumption.

2.5. Optical Port

Optical port feature enables data transfer and programming in compliance with EN 61107 communication protocol.

A receiver and a transmitter diode is used for optical communication. Communication interface provides all index info, index and demand data from past months, and enables officials to make authorized changes.

2.6. Sealing Spots

Embedded spots are found on the meter case to prevent intervention to the meter.

3. SECURITY NOTICES

The meters should be mounted/dismounted by authorized personnel.

The energy should be cut off while mounting/dismounting the meters.

After the mounting the meters, in case of intervention by any individual or organization apart from authorized personnel, the non-volatile memory will record this intervention.

4. LCD SCREEN INFORMATION

By the definition of MID regulation, on the LCD screen of LSM10

meters, there is 6 integers and 3 decimals.



Option 1



Option 2



Option 3

5. MENUS

5.1. Main Menu

When the device is connected to energy, the list indicating Total Import Active Energy menu will appear in terms of kWh on the LCD screen. At 5 second intervals T1, T2, T3, T4, Reactive Inductive, Reactive Capacitive, Demand, Total Export, Export T1, Export T2, Export T3, Export T4, Export Reactive Inductive, Export Reactive Capacitive, Export Demand, Date, Time and Serial Number menus will appear on the screen respectively and scroll automatically.



TOTAL CONSUMPTION TARIFF T

The menu that shows the total amount of energy consumed in the other defined tariff zones.



TARIFF T1

The menu is as records of the energy used at the specified time interval.



TARIFF T2

The menu is as records of the energy used at the specified time interval.



TARIFF T3

The menu is as records of the energy used at the specified time interval.



TARIFF T4

Menu reserved for weekend and season tariffs that the distribution company will prepare and take into action.



REACTIVE-INDUCTIVE SCREEN

Indicates the consumed reactive- inductive energy.

880 T1
00000 1065

REACTIVE-CAPACITIVE SCREEN
Indicates the consumed reactive- capacitive energy.

16.0 T1
P 00000.00 kW

DEMAND SCREEN
Indicates maximum positive active energy demand value for determined time interval.

280 T1
T 0000000000 kWh

EXPORT T TOTAL TARIFF
The menu that shows total export energy amounts, recorded from other defined tariff segments.

28.1 T1
T1 0000000000 kWh

EXPORT T1 TARIFF
The menu is as records of the export energy used at the specified time interval.

28.2 T1
T2 0000000000 kWh

EXPORT T2 TARIFF
The menu is as records of the export energy used at the specified time interval.

28.3 T1
T3 0000000000 kWh

EXPORT T3 TARIFF
The menu is as records of the export energy used at the specified time interval.

28.4 T1
T4 0000000000 kWh

EXPORT T4 TARIFF
Menu reserved for weekend and season tariffs that the distribution company will prepare and take into action.

780 T1
0000000000

EXPORT REACTIVE-INDUCTIVE SCREEN
Indicates the consumed export reactive-inductive energy.

680 T1
0000000000

EXPORT REACTIVE-CAPACITIVE SCREEN
Indicates the consumed reactive- capacitive energy.

0.92 T1
02:03:20 18

DATE SCREEN
Indicates the date of the meter.

0.9.1 T1
1:59:59

TIME SCREEN
Indicates the time of the meter.

000 T1
12345678

SERIAL NO SCREEN
Indicates the serial number of the meter.

5.2. Notifications



TERMINAL COVER REMOVAL NOTIFICATION

The visual on this notice on the screen indicates that terminal cover previously opened. In case of unauthorized execution of this process, warranty will be invalid and penalty fees may be incurred.



MAIN COVER REMOVAL NOTIFICATION

It indicates that main cover is opened. In case of unauthorized execution of this process, warranty will be void and penalty fees may be incurred.



LOW BATTERY NOTIFICATION

This notice appears on the screen when the battery level is lower than a certain voltage level.. When you see this sign, please inform authorized personnel and/or organization.



REAL TIME CLOCK FAILURE NOTIFICATION

This sign means Real-time clock is disrupted for any reason. In this case, the meters write the values at the "Tariff T1".



MAGNETIC INTERVENTION NOTIFICATION

This sign means there is a magnetic intervention to the meter.



WARNING NOTIFICATION



COMMUNICATION NOTIFICATION

If the meter is able to communicate the icon is displayed on the screen.



STATUS NOTIFICATION



MONEY NOTIFICATION

For prepaid meters, this symbol is shown on the display if credit is loaded.



LATCHING RELAY NOTIFICATION

Energy connected,

Energy disconnected

the status of latching relay is shown as above.



RTC ERROR NOTICE

Appears and remains on the lcd persistently after a real-time-clock error occurs.

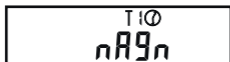

MAGNETIC INTERVENTION NOTICE

Shown on the screen if there is magnetic intervention on meter. Stays on the screen continuously.

NOTE: LCD screen display can be changed upon request.

5.3. Sub Menu

Sub Menu contents detail informations of meter memory.

To display "Sub Menu" on the screen, press and hold the menu button of the meter for 4 seconds. In the sub-menu; Voltage, Current, Power Factor, Frequency information and previous month information of T, T1,T2, T3, T4, Reactive inductive, Reactive Capacitive, Demand will appear on the screen respectively and scroll automatically.

To quit "Sub Menu", press and hold the menu button of the meter for 4 seconds.



Instant voltage screen



Instant current screen

33.70 T1
0000

Instant power factor screen

34.70 T1
F 00.00

Instant frequency screen

18.01 T1
T 0000000000 kWh

Total consumed active energy in previous month menu (T blinks)

18.11 T1
T1 0000000000 kWh

Total consumed energy T1 tariff in previous month menu (T1 blinks)

18.21 T1
T2 0000000000 kWh

Total consumed energy T2 tariff in previous month menu (T2 blinks)

18.31 T1
T3 0000000000 kWh

Total consumed energy T3 tariff in previous month menu (T3 blinks)

18.41 T1
T4 0000000000 kWh

Total consumed energy T4 tariff in previous month menu (T4 blinks)

58.01 T1
0000000000

Total consumed energy Reactive-Inductive in previous month menu

88.01 T1
0000000000

Total consumed energy Reactive-Capacitive in previous month menu

16.01 T1
P 0000000 kWh

Total demand in previous month menu (P blinks)

0.10 T1
00

Demand reset count

0.121 T1
20:10:20 18

Demand reset date

0.121 T1
1:59

Demand reset time

On the meters that have bidirectional communication (import-export) feature, previous month energy data of export energy is screened respectively on submenu.

6. SPHYSICAL DIMENSIONS OF THE METER

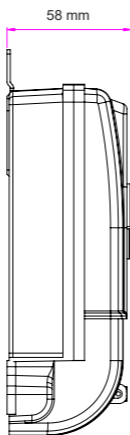
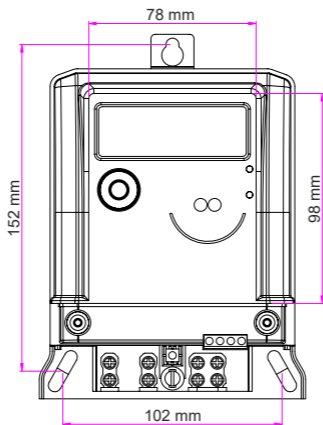

7. CONNECTIONS

7.1. Option 1

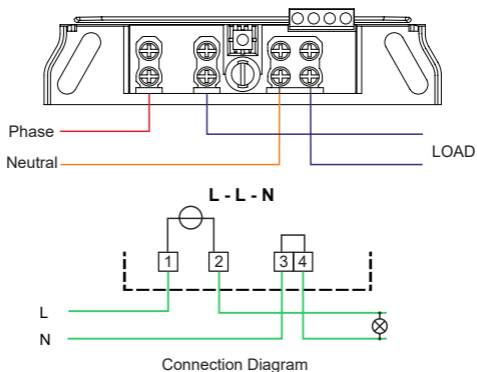

7.2. Option 2

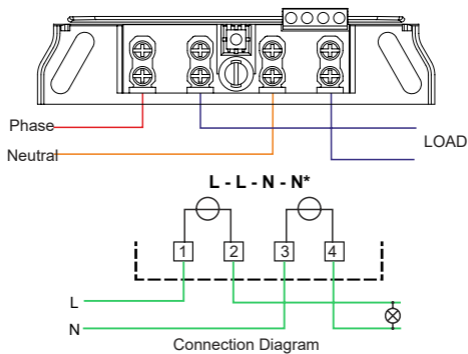

8. GENERAL MECHANICAL SCHEME

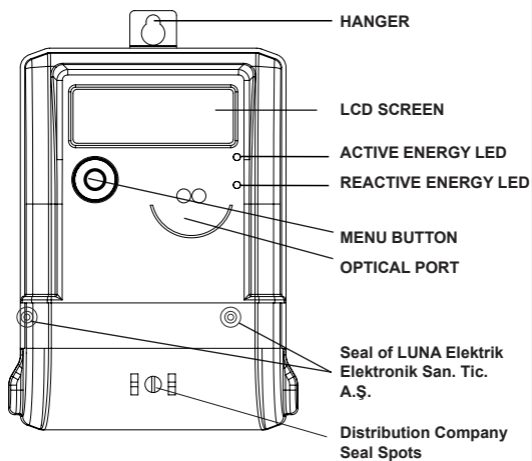

AB UYGUNLUK BEYANI

EU DECLARATION OF CONFORMITY

(No 0002)

1. Cihaz modeli/Cihaz

Instrument model/Instrument

: LSM10

Sayacın seri numarası:

Serial number of the meter:

2. Üretici adı ve adresi

Name and address of the manufacturer

: LUNA A.S.

10.001 Str. No:9

Ataturk O.S.B.

Cigli-Izmir-TURKEY

3. Bu uygunluk beyanı üreticinin sorumluluğu altında verilir.

This declaration of conformity is issued under the sole responsibility of the manufacturer.

4. Beyanın konusu:

Object of declaration:

5.

Yukarıda belirtilmiş olan uygunluk beyanı aşağıdaki ilgili AB uyumlandırma mevzuatı ile uyumludur:

The object of the declaration described above is in conformity with the relevant Union harmonisation legislation:

-Üye devletlerin ölçü aletleri pazarındaki uyumluluğu gerçekleştirmek üzere yasalarının uyumluluğu hakkındaki Avrupa Parlamentosu ve Konseyi'nin 2014/32/EU direktifi

-Directive 2014/32/EU of the European Parliament and of the Council of 26 February 2014 on the harmonisation of the laws of the member states relating to the making available on the market of measuring instruments.

-WELMEC Kılavuzu 11.1, Sayı 4
-WELMEC Kılavuzu 7.2, Sayı 5
-OIML R 46 -1/-2 Sürüm 2012 (E)
-Direktif 2015/13/EU

-Welmec Guide 11.1, Issue 4
-Welmec Guide 7.2, Issue 5
-OIML R 46 -1/-2 Edition 2012 (E)
-Directive 2015/13/EU

6. Uyumluluğun beyan edildiği ilgili standart referansları:

References to the relevant harmonised standards to which conformity is declared:

7. İlgili MODÜL B ve MODÜL D uygunluk değerlendirme prosedürlerini gerçekleştiren ve yayınlayan 1432 sayılı onaylanmış kuruluş (Slovenska legalna metrologia n.o.)

The notified body No. 1432 (Slovenska legalna metrologia n.o.) performed conformity assessment procedures MODULE B and MODULE D and issued:

AB Tip Onayı Belge No

EC type-approval certificate No

: SK14-048 MI-003

Kalite Yönetim Sistemi Onay No

Approval on a Quality Management System No

: SK-09-015D

8. Firma adına imza:

Signed for and on behalf of:

Tarih:

Date

Izmir,

Mustafa KARABAGLI

Yönetim Kurulu Başkanı

(Chairman of the Board)

24

**WARRANTY
CERTIFICATE**



WARRANTY PERIOD : 5 YEARS
TERM OF REPAIR : 20 BUSINESS DAYS

Customer

Brand LUNA

Type Electronic Electricity Meter

Model LSM10

Product

Serial Number

Name: LUNA ELEKTRİK ELEKTRONİK SAN. VE TİC. A.Ş.

Address: 10001 Sokak No:9 A.O.S.B. 35620 Çiğli / İZMİR

Tel& Fax: (0 232) 472 15 45 & (0 232) 472 15 50

e-mail: info@lunatr.com

APPROVAL

LUNA ELEKTRİK ELEKTRONİK
SANAYİ VE TİCARET A.Ş.
10001 Sokak No:9 A.O.S.B.
Çiğli / İZMİR
Çiğli V.D: 609 047 2390

Stamp-Signature

Vendor

Name:

Address:

Tel& Fax:

Invoice Date & Number:

e-mail:

WARRANTY TERMS

1. Warranty period begins with the delivery of good and for five (5) years.
2. Good is entirely covered by our warranty including all the parts.
3. In case of realizing defective good, consumer may use one of the rights situated in Law on Consumer Protection Law No. 6502, Article 11; **as reneged on contract, want discount from sale price, ask for free repaired, or want replacement by non-defective good.**
4. If consumer choose the right for asking free repaired, seller is responsible for repairing the good without asking any fee such as labor cost, cost of replacement parts, or under any other name. Consumers can use his right for free repaired to the manufacturer or importer. Dealer, manufacturer and importer are jointly and severally liable to consumer for realizing such right.
5. If consumer uses his right for **free repaired**, in case of good failure again during the warranty period, exceeding the maximum period of repair, stated that repair is not possible on a report given by authorized service station, seller, manufacturer or importer; consumer may demand **refund of good, discount of good regarding defective rate or replacement of good**. Seller cannot reject consumers demand., seller, manufacturer and importer are jointly and severally liable if there is failure to fulfill his demand, this demand.
6. In case of malfunction within the warranty period, repair period will be added to warranty period. Repair time for the good is maximum 20 days. This period begins by the notification of malfunction to service station, if service station is not available then to seller of good, dealer agent, representative importer or manufacturer. In case of failure cannot be resolved within 15 working days of the industrial product, the manufacturer or importer is obliged to provide to another industrial product with similar features to the consumer, until the completion of repair of the product.
7. Failures resulting from the use contrary to the matters located in the user manual for the product is out of warranty.
8. Consumer can apply to arbitration committee for consumer problems or the Consumer Court for the settlement of disputes that may arise regarding the use of the consumer rights for warranty.
9. If the warranty is not given by the seller, consumer may apply to Directorate General of Customs and Trade Ministry of Consumer Protection and Market Surveillance.
10. This product is manufactured regarding on the basis of the Law on Measurement and Settings No. 3516 .

POINTS TO CONSIDER REGARDING WARRANTY

This warranty presented by **LUNA Elektrik Elektronik San. ve Tic. A.Ş.**, does not cover following conditions as well as elimination of defects arising from the use of non-purpose.

1. The failures and damages that occur from misuse,
 2. Damaged and defects occurred while transportation, shipping, loading or unloading of product after delivery to user.
 3. Defects regarding installment is not assembled according to the installation and operating instructions and failures due to faulty connections,
 4. Products that guarantee label torn or unseal products,
 5. Fire, lightning, flood and earthquake (natural disasters), unsuitable environment and defects and damage occurring due to the accident,
 6. Interventions by unauthorized persons in case of a malfunction in the device,
- The elimination of failures mentioned above are charged.
- Warrant, is valid within the time specified on the other side of this document and applies only for product failures.
- If there is destruction and falsification on the warranty document, if the original serial number removed or destroyed, device guarantee automatically ended.

Main Technical Service:

LUNA Elektrik Elektronik San. ve Tic. A.Ş. 10001 Sokak No: 9 35620 Atatürk O.S.B. Çiğli / İZMİR Tel: +90 (0232) 472 15 45

TECHNICAL SPECIFICATIONS

TYPE	LSM10
Serial Number	
Nominal Voltage AC	230V _{AC}
Operating Voltage	-20%Un, +15%Un
Nominal Current (max) AC	5(100)A
Test Output	1000 imp/kWh
Starting Current mA	20mA
Nominal Frequency Hz	50 Hz ± %2
Method of Measurement	Directly connected to primary active-reactive meter
Accuracy Class	Class B
LCD Screen	6 integers, 3 decimals
Communication Protocol	RS485 / RF / GSM (optional)
P&P Comm. Modules	N/A
Protection Class	IP54 OUTDOOR
Relative Humidity	%95
Operating Temperature Range	-40 °C...+70 °C
T1 Tariff	T1 (06:00-17:00)
T2 Tariff	T2 (17:00-22:00)
T3 Tariff	T3 (22:00-06:00)
Daylight Saving Time	Last Sunday of March from 02:00 to 03:00 Last Sunday of October from 03:00 to 02:00
Battery Life	Operating: 10 years, shelf: 4 years
Weight	571 gr.



Phone: +90 232 472 15 45 Fax: +90 232 472 15 50

info@lunatr.com

www.lunatr.com