

TOP VIEW

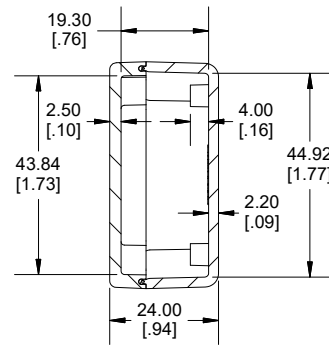

SECTION A-A  
END VIEW

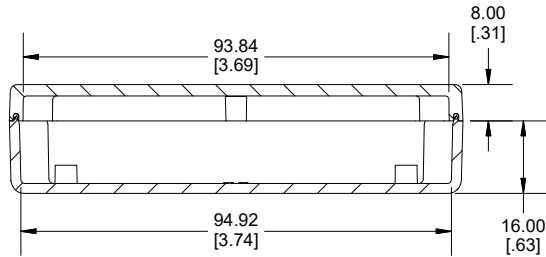

SECTION B-B  
SIDE VIEW

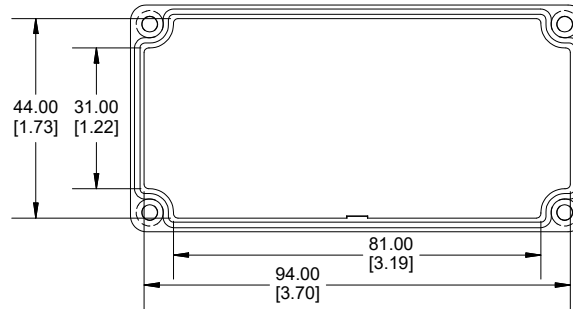

INSIDE LID



Enclosures can be Factory Modified (Milling, Drilling, Printing etc.)  
 Contact Factory ([modshop@hammfg.com](mailto:modshop@hammfg.com)) for quotes  
 Solid models of this enclosure available in .stp or .x\_t  
 (Part number and text placement/orientation on our products are subject to change,  
 we do not recommend using them as a locating reference for modification purposes)

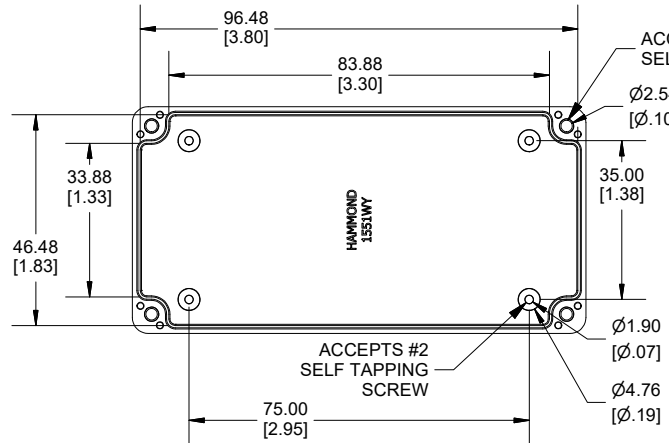

BOTTOM VIEW

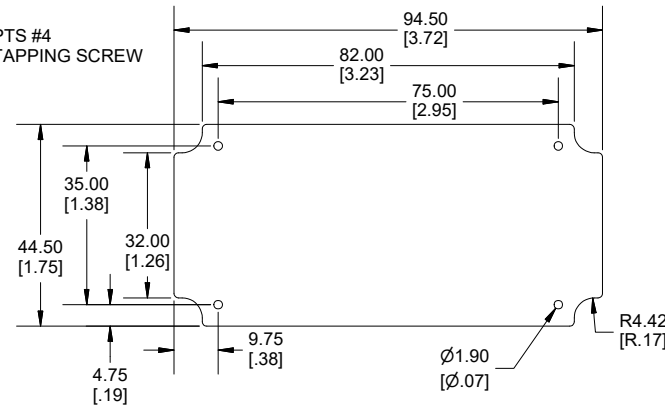

MAXIMUM  
P. C. BOARD

Dimensions:  
mm  
[inches]

**NOTE**

Purchased assembly includes box, lid, gasket, 4 cover screws.  
 Polycarbonate material is rated UL94 - V0

**Recommended Torque : #4 Cover screw (71-100) Ozf.in / (50-70) cN.m**

**Recommended Torque : #2 Internal screws (21-28) Ozf.in / (15-20) cN.m**

**PART NUMBERS**

| 1551WY Enclosure              |          |
|-------------------------------|----------|
| Polycarbonate Black Enclosure | 1551WYBK |
| Polycarbonate Gray Enclosure  | 1551WYGY |

**ACCESSORIES**

|  |                      |
|--|----------------------|
| Internal Mounting Post Screw<br>[#2 x 3/16" Plastite Self-tapping (4.8mm)] | 1553WTS100 (Pkg 100) |
| Stainless Steel Cover Screws<br>[#4 X 3/8" Plastite Self-tapping (9.5mm)]  | SC509-50 (Pkg 50)    |

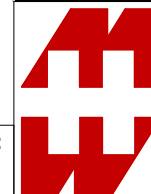

**HAMMOND  
MANUFACTURING®**

**1551WY**

[www.hammondmfg.com](http://www.hammondmfg.com)