

Ultraschallsensor A-14P20

Art.-Nr.: 700540

Specification : Waterproof type ultrasonic sensor

Item	Unit	Standard	Test condition: T=25±5°C
Function		Transmitting and receiving	
Terminal		Pin	
Housing Material		Aluminium	
Center frequency	KHz	40±1.0	
Transmitting S.P.L.	dB	>100	At 30cm/10Vrms Sine Wave 0dB=0.0002μ bar
Receiving Sensitive	dB	>-74	At 1V/μ bar
Directivity of X-axis	Deg	120±15	At "-6 dB" attenuation
Directivity of Y-axis	Deg	60±10	At "-6 dB" attenuation
Capacitance	PF	1600±20%	At 1KHz
Allowable Input Voltage (Vp-P)	V	140	At 40KHz Pulse width 0.4ms interval 10ms
Operating temperature	°C	-40~+80	
Storage temperature	°C	-40~+85	

Dimensions :

(Unit : mm)

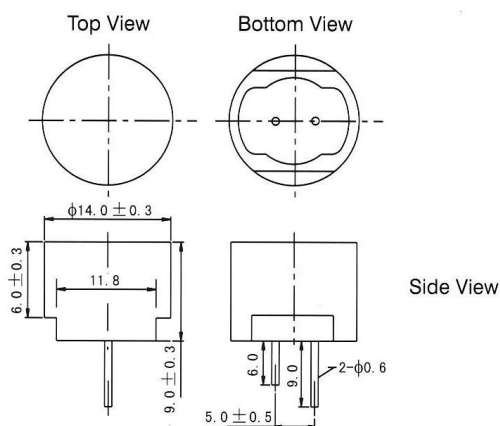

Directivity :

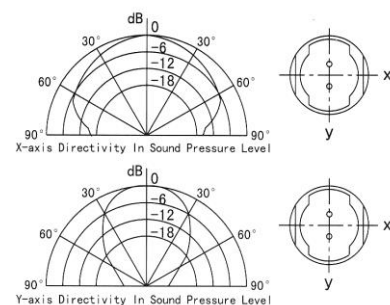

Version 1 / 10/2021