

1 2 3 4 5 6 7

FOR 客户名称	APPROVED 客户确认签字	ATTN 销售负责人

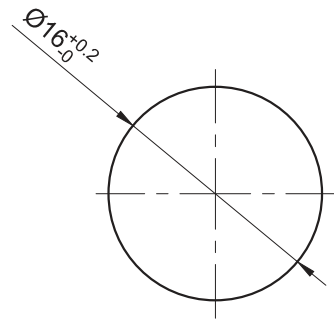

PANEL CUTOUT  
MAX.PANEL THICKNESS  
6 mm

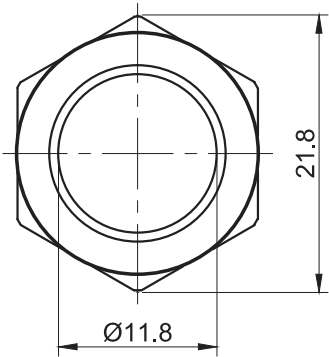
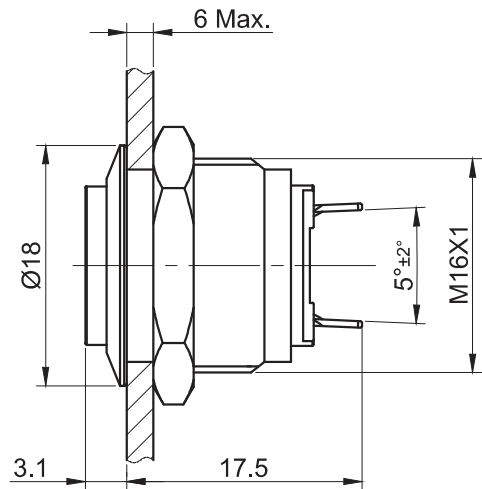
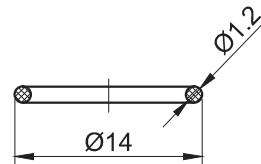

Seal Ring

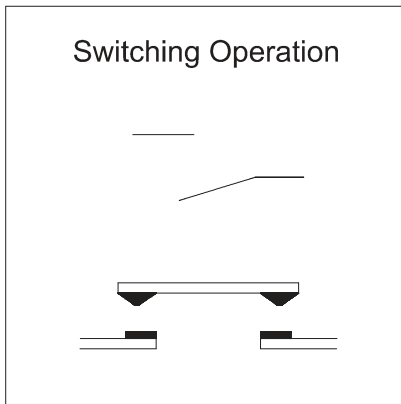

Part Number: GQ16H-10/J/◎

"◎"	Crust Material
N	Nickel Plated Brass
S	Stainless Steel
A	Al alloy(black)
G	Gold Plated Brass

**SPECIFICATIONS:**

- 1.Switch Rating: AC250V/0.5A, DC36V/2A.
- 2.Mechanical Life: ≥1,000,000cycles.
- 3.Electrical Life: ≥200,000cycles(DC 36V);  
≥50,000cycles(AC 220V).
- 4.Contact Resistance: ≤50mΩ.
- 5.Insulation Resistance: ≥1,000MΩ.
- 6.Dielectric Strength: 1,500V, RMS 50Hz, 1min.
- 7.Operating Temperature: -25°C~ +55°C(No Freezing).
- 8.Operating Force: About 4N.
- 9.Operating Travel: About 2mm.
- 10.Torque: About 0.6Nm max.applied to nut.
- 11.Protection degree: IP65;IK08.
- 12.Terminal Type: Pin Terminal(2 x 0.5mm).

**MATERIALS:**

- 1.Contact: Silver alloy.
- 2.Button: ◎.
- 3.Body: ◎.
- 4.Base: PA.

BRAND 品牌 <b>ONPOW</b>		红波按钮制造有限公司 ONPOW PUSH BUTTON MANUFACTURE CO.,LTD.	
THESE DRAWINGS AND SPECIFICATIONS ARE THE PROPERTY OF ONPOW PUSH BUTTON MANUFACTURE CO.,LTD. AND SHALL NOT BE REPRODUCED COPIED OR USED IN ANY MANNER WITHOUT THE PRIOR WRITTEN CONSENT OF ONPOW PUSH BUTTON MANUFACTURE CO.,LTD.		USED 用途	APPD 审核 CH 2020/04/13
SCALE 比例 1. □ / 1		FINISH 处理	CHKD 校对 NCH 2020/04/13
DIMENSIONS		UNIT 单位 mm	DR. 制图 ZPD 2020/04/13
0.00 TO 18.00mm	±0.43mm	TITLE 名称 GQ Series Anti-vandal push button	
18.01 TO 30.00mm	±0.52mm	DWG NO. 图号 GQ16H-10J	
30.01 TO 50.00mm	±0.62mm	FILE NAME 档案名称 GQ16-10J.DWG	
50.01 TO 80.00mm	±0.74mm	SHEET 张 1 / 1	REV. 更改 1
		SIZE 图纸 A4	

1 2 3 4 5 6 7