

**TOP VIEW**

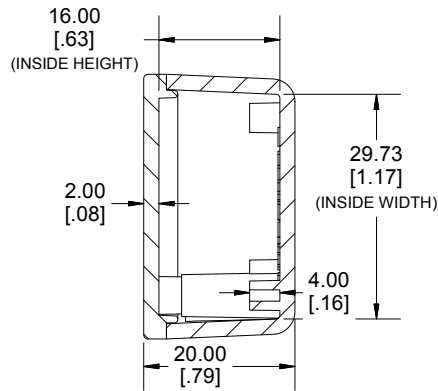

**END VIEW SECTION B-B**

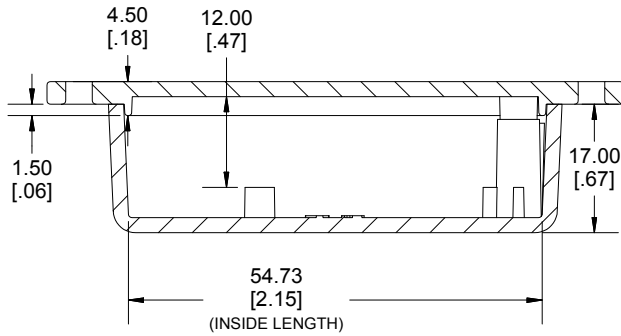

**SIDE VIEW SECTION A-A**

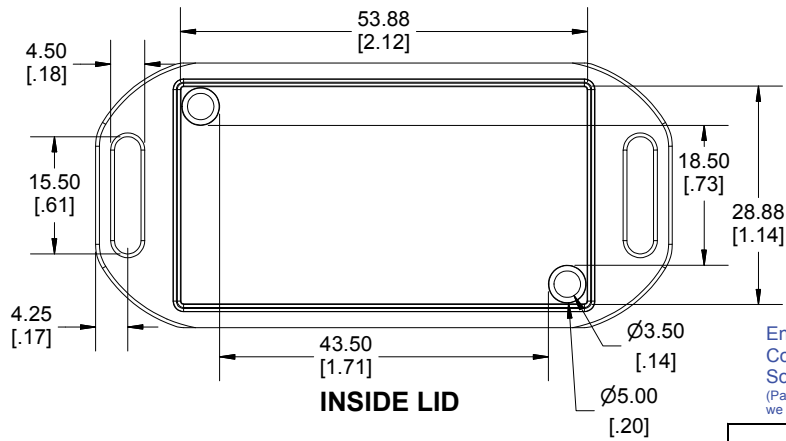

**INSIDE LID**

Enclosures can be Factory Modified ( Milling, Drilling, Printing etc.)  
 Contact Factory [mjm@hammondmfg.com](mailto:mjm@hammondmfg.com) for quotes  
 Solid models of this enclosure available in STEP or IGES.  
 (Part number and text placement/orientation on our products are subject to change, we do not recommend using them as a locating reference for modification purposes)

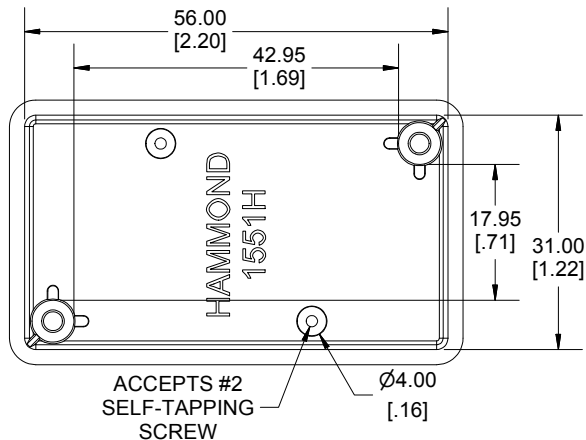

**INSIDE BOX**

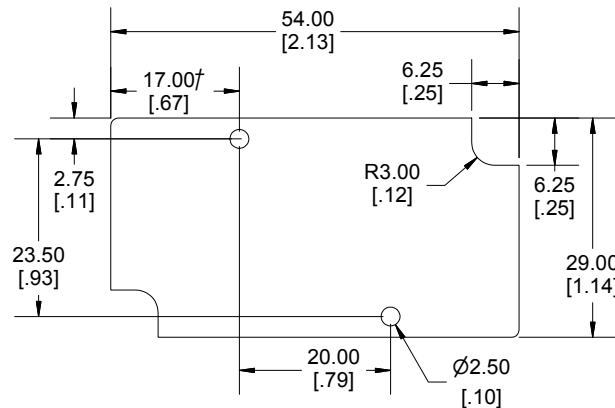

**MAXIMUM P.C. BOARD SIZE**

Dimensions:  
mm  
[inches]

NOTE		
Purchased assembly includes box, lid, 2 cover screws.		
Enclosure molded from general purpose ABS Plastic.		
Other materials / colours available consult factory.		
<b>Recommended Torque : (35-43) Ozf.in / (25-30) cN.m</b>		
PART NUMBERS		
1551HFL Enclosure		
Black Enclosure - Ral 9011 - UL94 - HB		1551HFLBK
Gray Enclosure - RAL 7035 - UL94 - HB		1551HFLGY
Translucent Blue - UL94 - HB		1551HFLTBU
ACCESSORIES		
Black Cover Screws #4 X 1/2" Self-tapping		1591TS100BK (Pkg 100)
Plated Cover Screws #4 X 1/2" Self-tapping		1591TS100 (Pkg 100)
P.C. Board Screws [#2 x 3/16" self-tapping (4.8mm)]		1551ATS100 (Pkg 100)

