

# USB to High-Speed Serial Chip CH343

Datasheet

Version: 1E

<http://wch.cn>

## 1. Introduction

CH343 is a USB bus converter chip, which converts USB to high-speed serial UART interface, supports automatic identification and dynamic adaptation of communication baud rate of 115200bps and below, provides common MODEM signal, to expand serial UART interface of computer or upgrade common serial devices or MCU to USB bus directly.

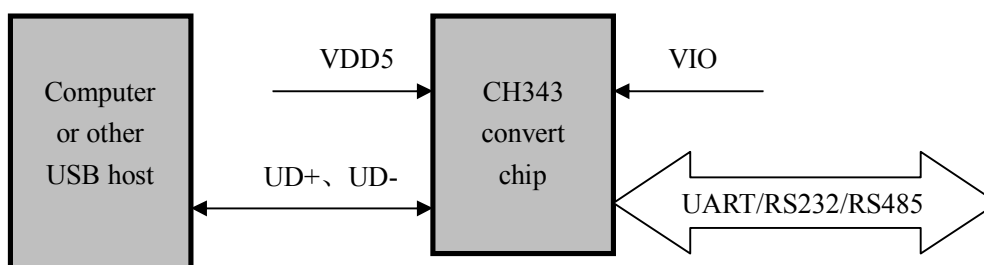

## 2. Features

- Full-speed USB device interface, USB 2.0 compatible.
- Built-in firmware, emulate standard UART interface, used to upgrade the original serial peripherals or expand additional serial UART via USB.
- Original serial applications are totally compatible without any modification.
- Supports free installation OS which built-in CDC driver or multifunctional high-speed VCP vendor driver.
- Hardware full-duplex serial UART interface, integrated independent transmit-receive buffer, supports communication baud rate varies from 50bps to 6Mbps.
- Supports automatic identification and dynamic adaptation of common communication baud rate of 115200bps and below.
- Supports 5, 6, 7 or 8 data bits, supports odd, even, space, mark and no parity.
- Supports common MODEM interface signals RTS, DTR, DCD, RI, DSR and CTS.
- Supports CTS and RTS hardware automatic flow control.
- Supports half-duplex, provides sending status TNOW which support RS485 to switch.
- Supports RS232 interface, through external voltage conversion chip.
- Supports USB port 5V and 3.3V power supply.
- I/O independent power supply, supports 5V, 3.3V, 2.5V and 1.8V power supply.
- Integrated power-on reset, integrated 12MHz clock, no external crystal required.
- CH343P integrates EEPROM used to configure the chip of VID, PID, maximum current value, vendor and product information string, etc.
- Chip has integrated Unique ID (USB Serial Number).
- RoHS compliant SOP-16, ESSOP-10 and QFN16 lead-free package.

### 3. Packages

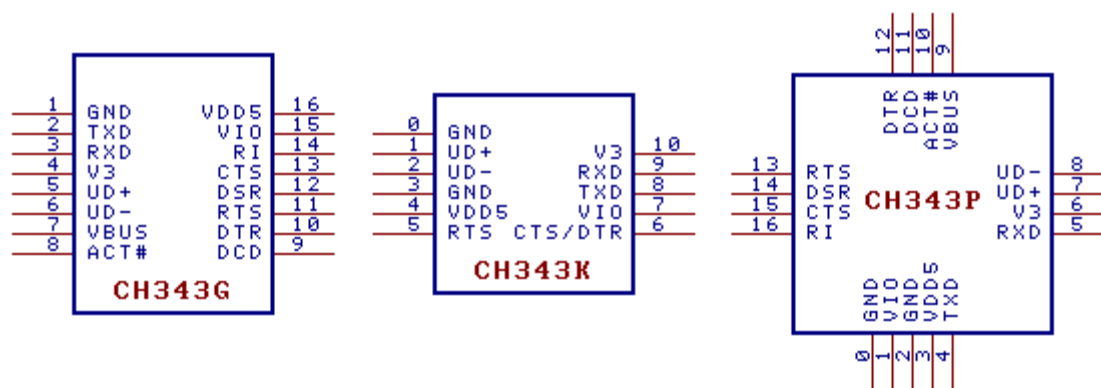

Package	Width Of Plastic		Pitch Of Pin		Instruction Of Package	Ordering Information
SOP16	3.9mm	150mil	1.27mm	50mil	Small outline 16-pin patch	CH343G
ESSOP10	3.9mm	150mil	1.00mm	39mil	Shrink Small outline 10-pin patch with backplane	CH343K
QFN16-3X3	3*3mm		0.5mm	19.7mil	Square leadless 16-pin	CH343P

Note: The backplane of the CH343K and CH343P is 0# pin GND, which is an optional but recommended connection; other GND are necessary connections.

USB transceiver of CH344 is designed in accordance with the USB2.0 full built-in design, UD+ and UD- pin cannot connect with resistor in serial, otherwise it will affect the signal quality.

### 4. Pin Out

SOP16 Pin No.	ESSOP10 Pin No.	QFN16 Pin No.	Pin Name	Pin Type	Pin Description
16	4	3	VDD5	POWER	Power supply voltage input of power regulator, requires an external decoupling capacitor
15	7	1	VIO	POWER	I/O port power input, requires an external decoupling capacitor
1	3, 0	2, 0	GND	POWER	Ground
4	10	6	V3	POWER	Internal power regulator output, core and USB power input, connect to VDD5 when VDD5 is less than 3.6V, connect to decoupling capacitor when VDD5 is more than 3.6V
NONE	NONE	NONE	RST	IN	Input of external reset, active low, integrated pull-up resistor
5	1	7	UD+	USB signal	Connect to USB D+ Signal directly, no external resistor
6	2	8	UD-	USB signal	Connect to USB D- Signal directly, no external resistor
7	NONE	9	VBUS	IN	VBUS status detection input of USB bus, integrated pull-down resistor

2	8	4	TXD	OUT	Transmit asynchronous data output, idle state is high level
3	9	5	RXD	IN	Receive asynchronous data input, integrated pull-up resistor
13		15	CTS	IN	MODEM input signal, clear to send, active low
	6		CTS or DTR	Default input, switch to output automati cally	Default is MODEM input signal, clear to send, active low, when computer software setting DTR is valid, automatically switch to MODEM output signal, data terminal ready, active low
12	NONE	14	DSR	IN	MODEM input signal, data set ready, active low
14	NONE	16	RI	IN	MODEM input signal, ring indicator , active low
9	NONE	11	DCD	IN	MODEM input signal, data carrier detect, active low
10	NONE	12	DTR TNOW	OUT	MODEM output signal, data terminal ready, active low, if an external pull-down resistor is detected during power-on, switch to a status indication about the serial port sending is in progress, active high
11	5	13	RTS	OUT	MODEM output signal, request to send, active low
8	NONE	10	ACT#	OUT	USB configuration completed state output, active low, if an external pull-down resistor is detected during power-on, switch to communication baud rate adaptive mode ,software can also use this mode

## 5. Function Descriptions

### 5.1. Internal Structure

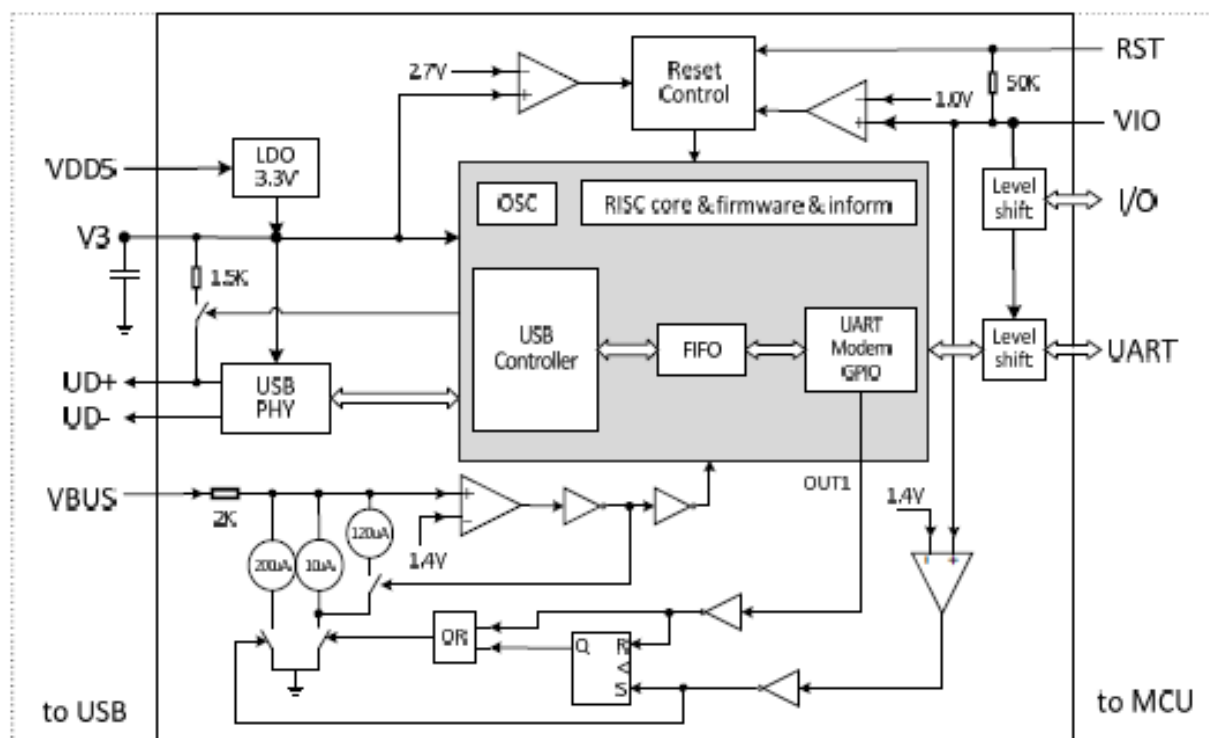

## 5.2. Power and Power Consumption

CH343 has 3 power supplies, built-in power regulator that generates 3.3V. VDD5 is the input of power regulator, V3 is the output of power regulator and USB transceiver and core power supply input, and VIO is the I/O pin power supply.

CH343 supports 5V or 3.3V supply voltage, the V3 pin should be connected to an external power decoupling capacitor of about 0.1uF. When using 5V power supply (more than 3.8V), VDD5 inputs external 5V power supply (for example, the USB bus power supply), the internal power regulator generates 3.3V on V3 which is used by USB transceiver. When using 3.3V or lower operating voltage (less than 3.6V), V3 should be connected to VDD5, input external 3.3V power supply simultaneously. V3 still requires an external decoupling capacitor.

The VIO pin of CH343 is used to provide I/O power for I/O and RST pin and supports 1.8V~5V supply voltage. VIO, MCU and other peripherals should use the same power supply. UD+, UD- and VBUS pin use V3 power supply, not use VIO.

CH343 automatically supports USB device suspension to save power consumption. In the USB suspend state, if the I/O output pin has no external load, the I/O input pin is floating (internal pull-up) or in a high level state, the VIO power supply will not consume current. In addition, when V3 and VDD5 lose power and are at 0V, the current consumption of VIO is the same as above, and VIO will not flow backwards current to VDD5 or V3.

VBUS should be connected to USB bus power supply, and when the loss of USB power is detected, CH343 will turn off the USB and sleep (suspend). CH343K has no VBUS pin, so assuming it always has been USB power, the integrated pull-down resistor of VBUS pin can be controlled by computer software which setting OUT1 signal of MCR serial register (SERIAL\_IOC\_MCR\_OUT1). Turning on the pull-down resistor When OUT1 is invalid (default status) or turn off it When OUT1 is valid.

CH343 provides VIO low-voltage protection mechanism when VBUS connects resistor in series to control VIO power through PMOS. During the shutdown of the VBUS pull-down resistor, if VIO voltage is lower than about 1.4V which is detected, then CH343 will automatically absorb about 300uA discharge current on VBUS, until the VIO voltage rises and the discharge current finished, starting the pull-down resistor automatically.

Several power connection schemes for reference here:

Power supply scheme	UART signals voltage MCU operating voltage	VDD5	V3	VIO	MCU or peripheral power supply
		Not less than V3 voltage	Rated around 3.3V	Both use the same power supply, 1.8V~5V	
All USB power supply	5V	USB powered 5V	Connects to capacitor only	USB powered 5V	
	3.3V	USB powered 5V	Connects to capacitor	V3 powered 3.3V, up to 10mA	
	3.3V	USB powered 5V stepped down to 3.3V via external LDO power regulator, V3 connects to external capacitor			
	1.8V~4V	USB powered 5V	Connects to capacitor only	USB powered, step-down via external LDO regulator	
USB+ self-powered Dual power supply	1.8V~5V	USB powered 5V	Connects to capacitor only	Self-powered 1.8V~5V (1.8V,2.5V,3.3V,5V)	
All self-powered	4V~5V	Self-powered 4V~5V	Connects to capacitor only	Self-powered 4V~5V	
	1.8V~5V	Self-powered, rated 3.3V, connects to external capacitor		Self-powered 1.8V~5V	

Recommended dual-power supply scheme, only VIO and MCU use the same power supply, low-current consumption. VIO current is only 2uA when USB suspend/sleep

### 5.3. UART

In serial UART mode, CH343 contains: data transfer pins, MODEM interface signals and assistant pins.

Data transfer pins contain: TXD and RXD. RXD is high when UART input is idle. TXD is high when UART output is idle.

MODEM interface signals contain: CTS, DSR, RI, DCD, DTR and RTS. All these MODEM interface signals are controlled and function defined by computer applications.

The DTR pin of CH343 is used as a configuration input pin during power-up and reset. It can be connected

to  $4.7K\ \Omega$  ( $3\sim 8K\ \Omega$ ) external pull-up resistor to generate a default low level, so that the serial port enters the half-duplex mode and switching the original DTR pin to TNOW pin to indicate that the serial port is sending data. In half-duplex mode, TNOW can directly control the receiving and sending switch of RS485 transceiver.

The CTS/DTR pin of CH343K is automatically switched from CTS to DTR (the default idle status is high level) when the computer software setting DTR is valid, and remains DTR output until the chip is re-powered on or reset. The DTR does not support the half-duplex mode input.

Assistant pins contain: ACT#. The ACT# pin is output of the USB device configuration completion status, which can be used to notify MCU or drive LED connected to VIO after connecting the current limiting resistor in series. The ACT# pin is used as a configuration input pin during power-up and reset. It can be connected to  $4.7K\ \Omega$  ( $3\sim 8K\ \Omega$ ) external pull-up resistor to generate a default low level, so that the serial port enters the communication baud rate self-adaption mode, which can automatically and dynamically identify common communication baud rate of 115200bps and below. It mainly supports common communication baud rate: 300, 600, 900, 1200, 1800, 2400, 3600, 4800, 9600, 14400, 19200, 28800, 33600, 38400, 56000, 57600, 115200, etc. Special high-speed communication baud rate: 10K, 20K, 30K, 50K, 100K, 150K, 250K, 300K, 500K, etc.

The UART of CH343 supports CTS and RTS hardware automatic flow control, which can be enabled by software. If enabled, UART only will continue to send the next data only when CTS input is valid (active low), otherwise the UART transmission will be stopped; UART will automatically set RTS to be valid (active low) when the receiving buffer is empty, it will automatically invalidate RTS until the data in the receiving buffer is nearly full, and RTS will be valid again when the buffer is empty. While using hardware automatic flow control, CTS of CH343 should connect to RTS of the counterpart, and RTS of CH343 should connect to CTS of the counterpart.

CH343 has integrated separate transmit-receive buffer and supports simplex, half-duplex and full-duplex UART communication. Serial data contains one low-level start bit, 5, 6, 7 or 8 data bits and 1 or 2 high-level stop bits, supports odd/even/mark/space parity. CH343 supports common baud rate: 50, 75, 100, 110, 134.5, 150, 300, 600, 900, 1200, 1800, 2400, 3600, 4800, 9600, 14400, 19200, 28800, 33600, 38400, 56000, 57600, 76800, 115200, 128000, 153600, 230400, 256000, 460800, 921600, 1M, 1.5M, 2M, 3M, 4M, 6M etc.

In applications with higher communication baud rate, it is recommended to enable hardware automatic flow control. Full-speed USB is only 12Mbps, considering the protocol overhead and other factors, in practical applications, the serial port should be avoided in a continuous or full-duplex of 3Mbps and above high-speed communication status.

The allowable baud rate error of CH343 UART receiving signal is less than 2%, the baud rate error of UART transmitting signal is less than 1.5%.

In the Windows OS, CH343 supports CDC driver that comes with system, and can install VCP vendor driver that supports high-speed communication. It can emulate standard serial port. So the mostly original serial applications are totally compatible, without any modification.

CH343 can be used to upgrade the original UART peripherals, or expand extra serial port for computers via USB bus, through external level shifting chip provides RS232, RS485, RS422 and other interface can be further.

#### 5.4. Clock , Reset and Others

CH343 has a built-in USB pull-up resistor, and the UD+ and UD- pins should be directly connected to the USB bus.

CH343 has built-in power-on reset circuit and low-voltage reset circuit. It also monitors the voltage of the V3 pin and the VIO pin. When the voltage V3 is lower than VRV3 or the VIO is lower than VRVIO, the chip will automatically reset hardware.

CH343 has built-in clock generator, without external crystal and oscillation capacitor.

#### 5.5. Parameter Configuration

In larger batch applications, the vendor VID and product identification PID of CH343 and product information can be customized.

In less batch applications, it can use CH343 that built-in EEPROM. After user installs VCP vendor driver, through configuration tool CH343xSerCfg.exe provided by chip manufacturer, it can be flexibly configured the vendor VID, product identification PID, maximum current, BCD version number, vendor information and product information string descriptor, etc.

### 6. Parameters

#### 6.1. Absolute Maximum Ratings

(critical state or exceeding maximum can cause chip to not work or even be damaged)

Name	Parameter Description	Min.	Max.	Unit
TA	Operating Ambient Temperature	-40	85	°C
TS	Storage Temperature	-55	125	°C
VDD5	USB Supply Voltage(VDD5 connects to power, GND to ground)	-0.5	6.0	V
VIO	I/O Supply Voltage(VIO connects to power, GND to ground)	-0.5	6.0	V
VVBUS	VBUS Voltage	-0.5	6.5	V
VUSB	USB Signal Voltage	-0.5	V3+0.5	V
VUART	UART And Others Voltage	-0.5	VIO+0.5	V

#### 6.2. Electrical Parameters

(test conditions: TA=25°C, VDD5=5V or VDD5=V3=3.3V, VIO=1.8V~5V, exclude USB pin)

Name	Parameter Description		Min.	Typ.	Max.	Unit	
VDD5	USB supply voltage	V3 doesn't connect to VDD5, V3 connected to capacitor	4.0	5	5.5	V	
		V3 connected to VDD5, VDD5=V3	3.0	3.3	3.6		
VIO	Serial port and other I/O supply voltage		1.7	5	5.5	V	
IVDD	Operating VDD5 or V3 supply current			3	15	mA	
IVIO	Operating VIO supply current(depend on load)			0	(10)	mA	
ISLP	Suspending USB supply current	VDD5 power supply =5V		0.09	0.16	mA	
		VDD5=V3 power supply =3.3V		0.085	0.15	mA	
		VIO power supply, no I/O load/pull up		0.002	0.05	mA	
ILDO	External load capacity of internal power regulator				10	mA	
VIL	Low-level input voltage	VIO=5V	0		1.5	V	
		VIO=3.3V	0		0.9	V	
		VIO=1.8V	0		0.5	V	
VIH	High-level input voltage	VIO=5V	2.5		VIO	V	
		VIO=3.3V	1.9		VIO	V	
		VIO=1.8V	1.3		VIO	V	
VIHVBS	VBUS high level voltage	VIO=1.8~5V	1.7		5.8	V	
VOL	Output low voltage	VIO=5V, draw 15mA current		0.4	0.5	V	
		VIO=3.3V, draw 8mA current		0.3	0.4	V	
		VIO=1.8V, draw 3mA current		0.3	0.4	V	
VOH	Output high voltage, not reset status	VIO=5V, output 10mA current	VIO-0.5	VIO-0.4		V	
		VIO=3.3V, output 5mA current	VIO-0.4	VIO-0.3		V	
		VIO=1.8V, output 2mA current	VIO-0.4	VIO-0.3		V	
IPUP	Pull-up current of serial port and RST (pull-up to VIO voltage)		VIO=5V	35	150	220	uA
			VIO=3.3V	15	60	90	uA
			VIO=1.8V	3	14	21	uA
IPDN	Pull-down current of VBUS		VBUS>1.6V	6	10	16	uA
			VBUS<1.3V	50	140	200	uA
VRV3	V3 Power-on reset/low voltage reset voltage threshold		2.5	2.7	2.9	V	
VRVIO	VIO power supply low voltage reset voltage threshold		0.8	1.0	1.15	V	
VESD	HBM ESD withstand voltage of USB or I/O		5	6		KV	

### 6.3. Timing Parameters

(test conditions: TA=25°C, VDD5=5V or VDD5=V3=3.3V, VIO=1.8V~5V)

Name	Parameter Description	Min.	Typ.	Max.	Unit	
FD	Error of internal clock (influence baud rate comparatively)	TA=-15°C~60°C	-1.0	±0.5	+1.0	%
		TA=-40°C~85°C	-1.5	±0.8	+1.5	%
TRSTD	Reset delay after power on or external reset input	9	15	25	mS	
TSUSP	Detect USB automatic suspend time	3	5	9	mS	
TWAKE	Wake-up completion time after chip sleep	1.2	1.5	5	uS	

## 7. Applications

### 7.1. USB to 9-wire TTL Converter Configuration

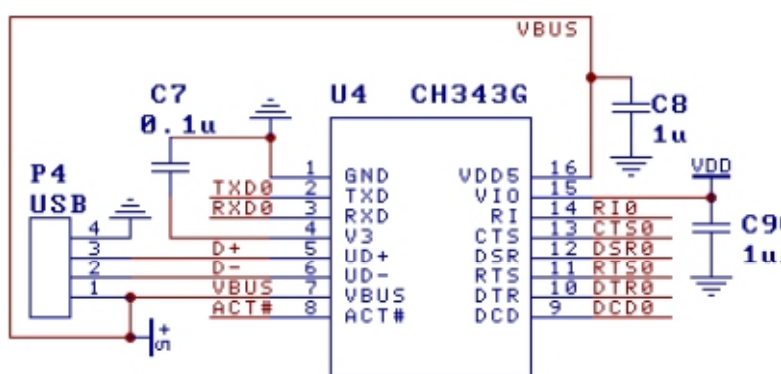

The image above is the USB to TTL converter realized by CH343G. The signal in the image can only be connected to RXD, TXD and public ground, while using the others as needed, all can be suspended when not needed.

P4 is USB port, USB bus contains a pair of 5V power lines and a pair of data signals. Usually, the color of +5V power line is red, the black is ground. D+ signal line is green and the D- is white. The supply current provided by USB bus is up to 500mA. The VBUS pin detects the power supply status of USB here.

Three power supply schemes: The first is all USB powered supply. CH343 chip and USB products directly use the 5V power supply provided by the USB bus, that is, VDD5=VBUS=USB 5V power, VIO=VMCU=USB 5V or 1.8V~4V after step-down; The second is separate and independent power supply. The VIO of CH343 and the MCU of the product use self-standing power VDD, while CH343 uses USB power, and VDD5 is connected to the USB power VBUS, that is, VDD5=VBUS=USB 5V power, VIO=VMCU=VDD=self-powered 1.8V~5V; The third is all self-powered, only detecting but not using USB power, USB product provides standing power VDD through self-powered mode, mainly contain two ways: VDD5=VIO=VMCU=VDD=self-powered 5V or VDD5=V3=VIO=VMCU=VDD=self-powered 3.3V.

The capacitor C7 on V3 is 0.1uF, used to CH343 internal power node decoupling. C8 and C9 are used for external power decoupling.

When designing the PCB, pay attention to: decoupling capacitor C7, C8 and C9 get as close to the connected pins of CH343 as possible; Enabling the D+ and D- signal lines close to the parallel wiring, and providing

ground or copper on both sides to reduce signal interference from the outside.

### 7.2. USB to RS232 Converter Configuration (9-wire)

CH343G provides common UART and MODEM signals, converts TTL to RS232 through external level shifting chip U2. P2 Port is DB9, the pins and functions are the same as common DB9 of PC. The chips similar with U2 have MAX213/ADM213/SP213/MAX211 etc.U2 uniformly powered by the USB bus through R4.

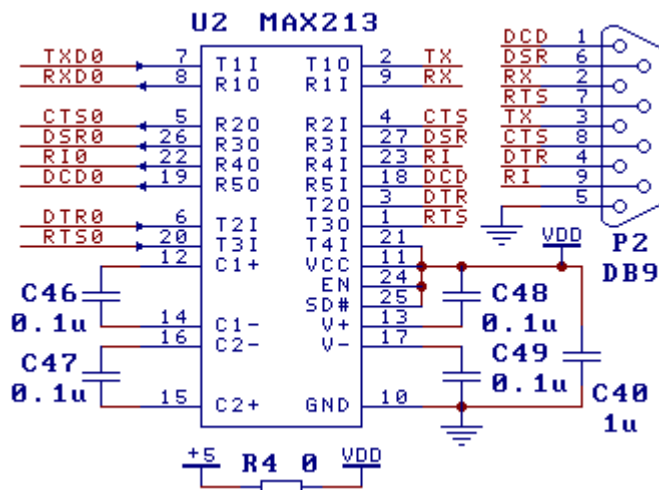

### 7.3. USB to RS485 Converter Configuration

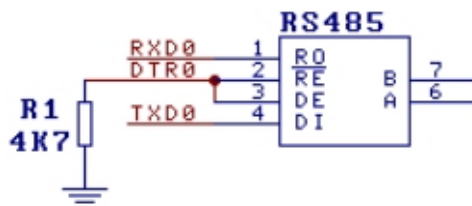

In the image, DTR connects to external pull-down resistor, therefore switching to TNOW which can be used to control DE (high active send enable) and RE# (low active receive enable) pin of RS485 transceiver.

### 7.4. Connect CH343 to MCU and Supply Power Separately

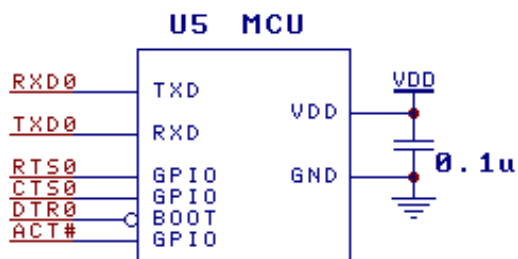

The image above shows the reference circuit that the MCU connect to CH343 through TTL to realize USB communication in dual power supply mode. VBUS is powered by CH343 through USB bus, the MCU and VIO use another self-powered VDD, which supports 5V, 3.3V or even 2.5V, 1.8V.

Excepting RXD and TXD, other pins are optional connections.

If the serial port speed is higher, the MCU can realize hardware flow control through CTS and RTS.

If needed, VBUS (OUT1) also used to control PMOS power switch that VBUS supplies power to MCU. As show below: +5 is USB power, VDD is VIO and MCU power of CH343. In default, the pull-down resistor of VBUS is turned on and generated a pull-down current, enabling the PMOS grid has enough voltage to turn on, and VBUS supplies power to VIO. After the computer software has set RTS and CTS, setting OUT1 is valid; then the pull-down resistor of VBUS is turned off, finally, the VIO drops voltage, which result MCU low voltage reset. When the VIO voltage drops to about 1.4V, low-voltage protection mechanism of VIO is triggered, VBUS automatically absorbs the pull-down current and regains the pull-down resistor, enabling PMOS is turned on again and resuming the supply power of the VIO. The whole process has achieved VIO step-down and MCU reset. The luminous tube D1 is used to prevent the VBUS voltage being too low. In addition, connecting a series diode between Q1 and VDD can prevent VDD from flowing back to +5.

