

# BCK BINARY CODED ROTARY SWITCH

## GENERAL ELECTRICAL & MECHANICAL SPECIFICATION

**RoHS COMPLIANT**

Switch Rating:	150mA@50Vac/dc resistive only
Life:	>10,000 Cycles
Operating Temperature:	-30°C to +85 °C
Proof Voltage:	250Vac (Initial)
Insulation Resistance:	>999 MΩ at 500Vdc (Initial)
Contact Resistance:	<50 mΩ (Initial)
Operating Torque (nominal)	Standard 4.7 ± 0.5 cNm
End Stop Torque (nominal):	0.8 Nm
Moulding Material:	Polyamide 6.6 G.F.
Contact/Terminal Material:	Brass CZ108 Ag Plated



## GENERAL FEATURES

- Made in UK
- Binary coded Hexadecimal and complimentary versions.
- Moulded 27.5mm diameter single wafer switch.
- Standard 22.5° indexing
- Printed Circuit Terminals.
- Adjustable stop to restrict number of positions or continuous rotation.
- Special options include UL-V0 rated material, gold flashed or gold plated (2.5 microns gold over 2 microns nickel) contacts, spindles with special flats or slots.

## STANDARD PART NUMBER

BASIC TYPES	SPINDLE DIAMETER	SPINDLE LENGTH FROM MOUNTING FACE	8mm LONG BUSH	SPINDLE FLAT LENGTH	ANGLE OF SPINDLE FLAT	SPINDLE FLAT THICKNESS
IMPERIAL	6.35mm	38mm	9.52 x 32TPI	30mm	90°	5.5mm
METRIC	6.00mm	50mm	M10 x 0.75	No Flat	---	---

		STANDARD METRIC		STANDARD IMPERIAL	
		Stop	No Stop	Stop	No Stop
Hex (Code 033) – Standard Spindle		BCK1002 (no lug)	BCK1001 (no lug)	BCK1006 (lug)	BCK1005 (lug)
Comp (Code 043) – Standard Spindle		BCK1004 (no lug)	BCK1003 (no lug)	BCK1008 (lug)	BCK1007 (no lug)
Hex (Code 033) – Flush Slot		-	BCK1009 (lug)	BCK1014 (lug)	-
Comp (Code 042) – Flush Slot		-	-	BCK1019 (lug)	BCK1020 (lug)

( please see drawing detail for lug reference)

DIAL	COMMON E Connection to Terminals			
	A	B	C	D
1	•			
2		•		
3	•	•		
4			•	
5	•		•	
6		•	•	
7	•	•	•	
8				•
9	•			•
10		•		•
11	•	•		•
12			•	•
13	•		•	•
14		•	•	•
15	•	•	•	•
16				

LORLIN BINARY CODED HEXADECIMAL COMPLIMENTARY COMMON –16 POSITIONS

**CODE 033**

DIAL	COMMON E Connection to Terminals			
	A	B	C	D
1				
2				•
3			•	
4			•	•
5		•		
6		•		•
7		•	•	
8		•	•	•
9	•			
10	•			•
11	•		•	
12	•		•	•
13	•	•		
14	•	•		•
15	•	•	•	
16	•	•	•	•

LORLIN BINARY CODED HEXADECIMAL NON COMPLIMENTARY COMMON –16 POSITIONS

**CODE 042**

DIAL	COMMON E Connection to Terminals			
	A	B	C	D
1	•	•	•	•
2	•	•	•	
3	•	•		•
4	•	•		
5	•		•	•
6	•		•	
7	•			•
8	•			
9		•	•	•
10		•	•	
11		•		•
12		•		
13			•	•
14			•	
15				•
16				

LORLIN BINARY CODED HEXADECIMAL COMPLIMENTARY COMMON –16 POSITIONS

**CODE 043**

# BCK BINARY CODED ROTARY SWITCH

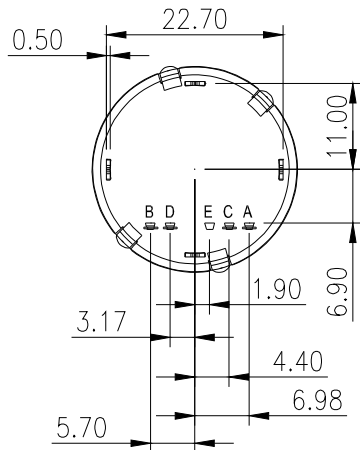

CUSTOMER TO COMPLETE OR DELETE AS REQUIRED

	A	B	C
IMPERIAL	Ø6.35		Ø9.52 x 32TPI
METRIC	Ø6.00		M10 x 0.75

	D	E	F
IMPERIAL			
METRIC			

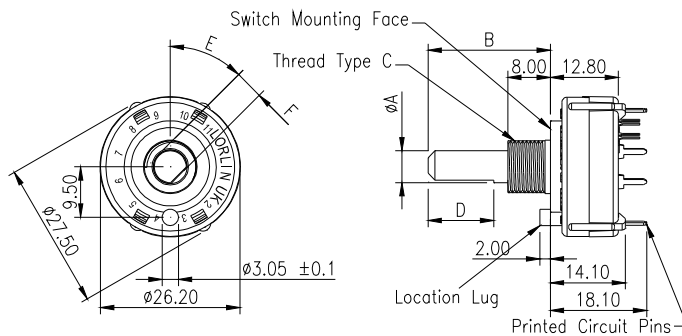

## STANDARD SPINDLE DETAILS

	A	B	C	D	E	F
BASIC TYPES	SPINDLE DIAMETER	SPINDLE LENGTH FROM MOUNTING FACE	8mm LONG BUSH	SPINDLE FLAT LENGTH	ANGLE OF SPINDLE FLAT	SPINDLE FLAT DEPTH
IMPERIAL	6.35mm	38mm	9.52 x 32TPI	30mm	90°	5.5mm
METRIC	6.00mm	50mm	M10 x 0.75	No Flat	---	---

## STANDARD ANGLES OF SCREWDRIVER SLOTS

Standard screwdriver slots are 1.2mm wide and 1.5mm deep.



## TYPICAL SPINDLE DETAILS



Orientation with location lug in position shown.

## TO ORDER PLEASE SPECIFY:

1. Switching Code
2. Imperial or Metric Spindle Diameter
3. Dimension (B) Spindle length from Mounting Face
4. Thread Required (C)
5. Spindle Flat length if required (D)
6. Angle of Flat (E)
7. Spindle Flat Depth (F)
8. 16 Position or No Stop Version
9. Contact Plating: Silver/Gold Flash/2.5 microns Gold Plate
10. Location Lug if required

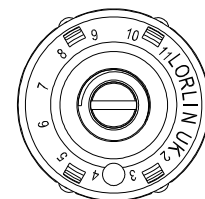

### EXAMPLE

Screwdriver slot level with top of threaded fixing bush 1.2mm wide x 1.5mm deep (standard) at 90° (standard)