

## 160pcs 5mm Standard LED with 300mm Cable assortment with LED mount and pre-resistor Item No.: 18010012

This range of experiments and practitioners with superbright standard LEDs with a diameter of 5 mm, approx. 30 cm flexible strands (stand on) and various series resistors is ideal for immediate start in experiments with semiconductor light. Through resistor combinations of parallel or series connection or varying the supply voltage, different operating currents (brightnesses) can be realized. Addition LED mounting clips for easy mount and installation onto casing or panel.

A brief description of the components contained is clearly printed on the inside of the lid.



### Carbon Film Fixed Resistor

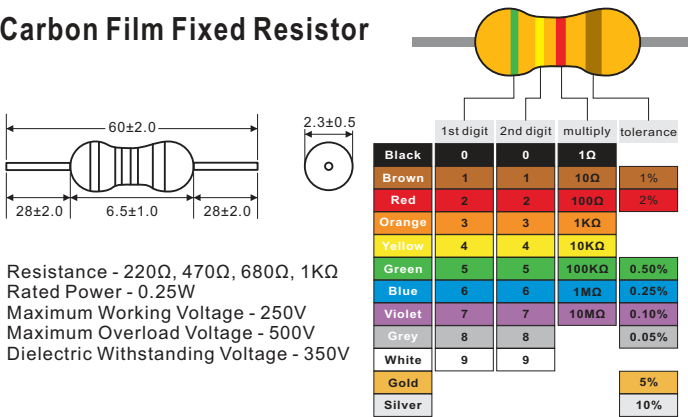

Resistance - 220Ω, 470Ω, 680Ω, 1KΩ  
 Rated Power - 0.25W  
 Maximum Working Voltage - 250V  
 Maximum Overload Voltage - 500V  
 Dielectric Withstanding Voltage - 350V

### LED Mounting Clips

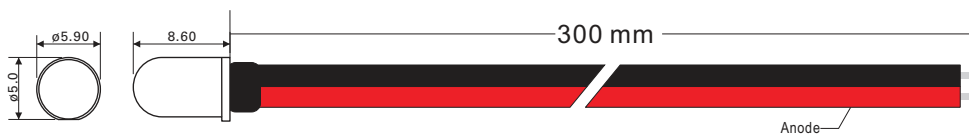
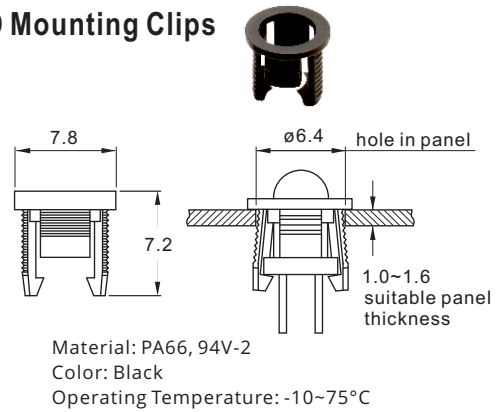

Achtung: Leuchtdioden müssen immer durch Vorwiderstand oder Konstantstromquelle strombegrenzt werden!  
 Attention: Do not drive LEDs without forward-current limitation (pre-resistor or constant current source)

Light Source	Red	Blue	Green	Yellow	Cold White	Warm White
Lens color	Diffuse	Diffuse	Diffuse	Diffuse	Water clear	Water clear
Chip material	Gap	InGaAIP	InGaAIP	Gap	InGaAIP	InGaAIP
Wavelength / color temperature	620-625nm	460-470nm	568-572nm	587-590nm	7000-9000K	2800-3200K
Max. Luminous intensity	800 mcd	2000 mcd	120 mcd	800 mcd	14000 mcd	20000 mcd
Viewing angle (typ.)	35°	35°	35°	35°	20°	25°
Forward current (max.)	20 mA	30 mA	20 mA	30 mA	20 mA	20 mA
Forward voltage (typ.)	2.0 V	3.0 V	3.0 V	2.0 V	3.0 V	3.0 V
Operating temperature	-25°C - 80°C					
Storage temperature	-30°C - 100°C					